

TS0808ZZ-50R0JN-2S Features:

- Single-Sided Terminal Configuration
- Solder or Epoxy Attachment
- RoHS Compliant or SnPb Available
- Customer Defined Testing Available
- ±5% Resistor Tolerance
- Waffle Pack Available (Standard is Bulk)

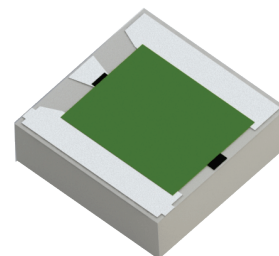

Actual Size

TS0808ZZ-50R0JN-2S Parameters:

Operating Frequency:	DC - 44GHz
CW Rated Power:	1W*
Peak Rated Power (at 30% Duty Cycle):	20W for 10μ Seconds 10W for 50μ Seconds 5W for 100μ Seconds 2.5W for 500μ Seconds 1.5W for 1000μ Seconds
Return Loss (Typical)**:	20dB or Better
Impedance:	50Ω ±5%***
Resistor Construction:	Thick Film on AIN
Operating Temperature:	-55 to +150°C

TS0808ZZ-50R0JN-2S Power Derating Curve

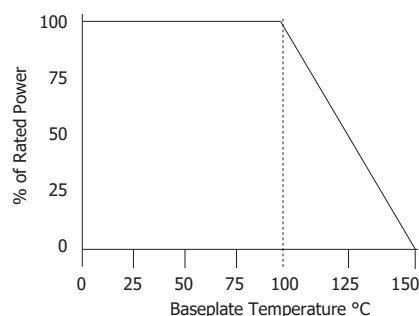

TS0808ZZ-50R0JN-2S Dimensions:

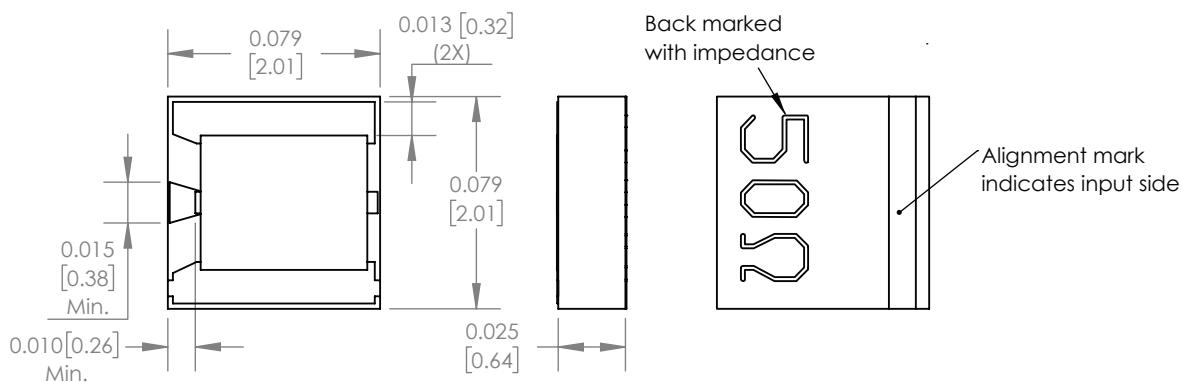

Dimensions in inches [mm].
Tolerance is ± 0.005 [0.254] unless otherwise stated

* Rating based on ≤100°C constant baseplate temperature
** In a matched, continuous 50Ω system with proper workmanship
*** Other values and tolerances available. Contact factory.

TS0808ZZ-50R0JN-2S Ordering Information

TS	0808	ZZ	-	50R0	J	N	-	2S	UU
Prefix for Chip Termination w/ Single-Sided Terminals				Value Code 50R0 - 50Ω	Tolerance J - 5%	Normal Inspection Contact factory for additional options		Substrate 2S - 0.025" AIN	Packaging Blank - Bulk WP - Waffle Pack
Size 0808									
Terminal Metallization			RoHS	Magnetic	Solder	Epoxy	Wirebond		
BA -	Palladium Silver		Yes	No	Yes	Yes	No		
CB -	SnPb over Nickel over Silver		No	Yes	Yes	No	No		
CT -	Matte Tin over Nickel over Silver		Yes	Yes	Yes	No	No		

Barry Industries reserves the right to change part number and/or process without notification.

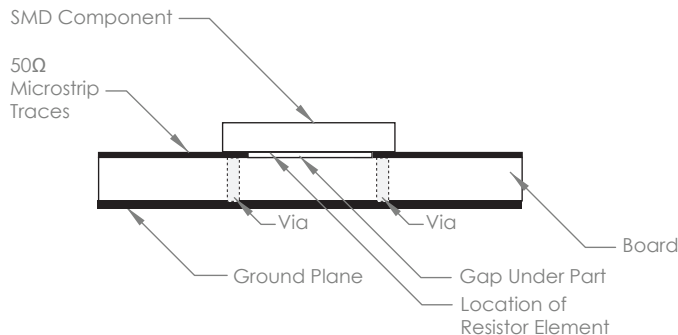
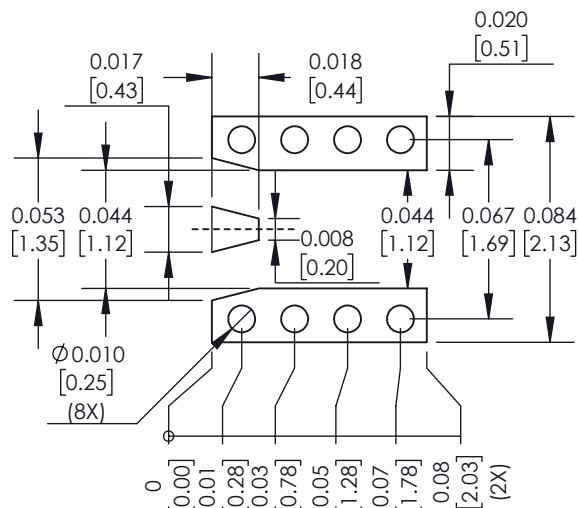
TS0808ZZ-50R0JN-2S Recommended Pad Layout & Mounting Configuration:

TS0808ZZ-50R0JN-2S Reliability Specifications:

Parameter:	Test Condition:	Results:
Short Time Overload	Apply 1.1x Rated Power for 5 Seconds.	≤ 5.0% Resistance Shift
Rated Load Life	Apply 1/2 Power Under 40°C ±2°C 90 Minutes on/ 30 Minutes off. Repeat for 100 hours	≤ 5.0% Resistance Shift
Moisture Resistance	MIL-PRF-55342 para 4.8.9 95% RH, 25°C - 65°C	≤ 5.0% Resistance Shift
Resistance to Soldering Heat	MIL-STD-202 Method 210 and MIL-PRF-55342 Para 4.8.8.1	≤ 5.0% Resistance Shift
Solderability	MIL-PRF-55342 Para 4.8.12	>95% Covered
High Temperature Storage	125°C ±2°C for 500 Hours	1.) ≤ 5.0% Resistance Shift 2.) No Significant Abnormality (Visual)
Thermal Shock	-65°C to +150°C 30 Minutes Dwell, 5 Cycles	1.) ≤ 5.0% Resistance Shift 2.) No Significant Abnormality (Visual)

Barry Industries reserves the right to change part number and/or process without notification.