

Product name	Description	Version
ST-1612i-DGX	Datasheet of ST-1612i-DGX multiple GNSS module	1.5



1 Introduction

The LOCOSYS ST-1612i-DGX Dead Reckoning (DR) module is the perfect solution for automotive application. The ST-1612i-DGX is embedded 3D accelerometer, 3D gyroscope Micro-Electro-Mechanical Systems (MEMS) sensor, equipped with DR software, and powered by STMicroelectronics Teseo III. With adverse GNSS conditions in urban canyons, tunnels, or parking garages where DR boosts the accuracy, and the software fills the gaps. It supports three dimensional DR. This module can simultaneously acquire and track multiple satellite constellations that include GPS, GLONASS, GALILEO and QZSS. It features high sensitivity, low power and ultra small form factor, and provide user the superior performance.

ST-1612i-DGX modules use GNSS chips qualified according to AEC-Q100 and manufactured in IATF 16949 certified sites.

2 Features

- STMicroelectronics Teseo III high sensitivity solution
- AEC-Q100 qualified for automotive grade
- Support GPS, GLONASS, GALILEO and QZSS
- Capable of SBAS (WAAS, EGNOS, MSAS)
- Fast TTFF at low signal level
- Built-in Dead Reckoning (DR) software
- Built-in MEMS sensor (3-axis Gyroscope and 3-axis Accelerometer)
- Support Odometer (wheel-tick pulse) input
- Support Forward / Reverse Direction (FWD) input
- Support sensors data feed through the UART port
- Support SAE J2945/1 On-board system requirement for V2V safety communication
- IATF 16949 quality control
- Support CAN Bus (ISO 15765-4)
- Small form factor 16 x 12.2 x 2.3 mm
- SMD type, RoHS compliant

3 System Block Diagram

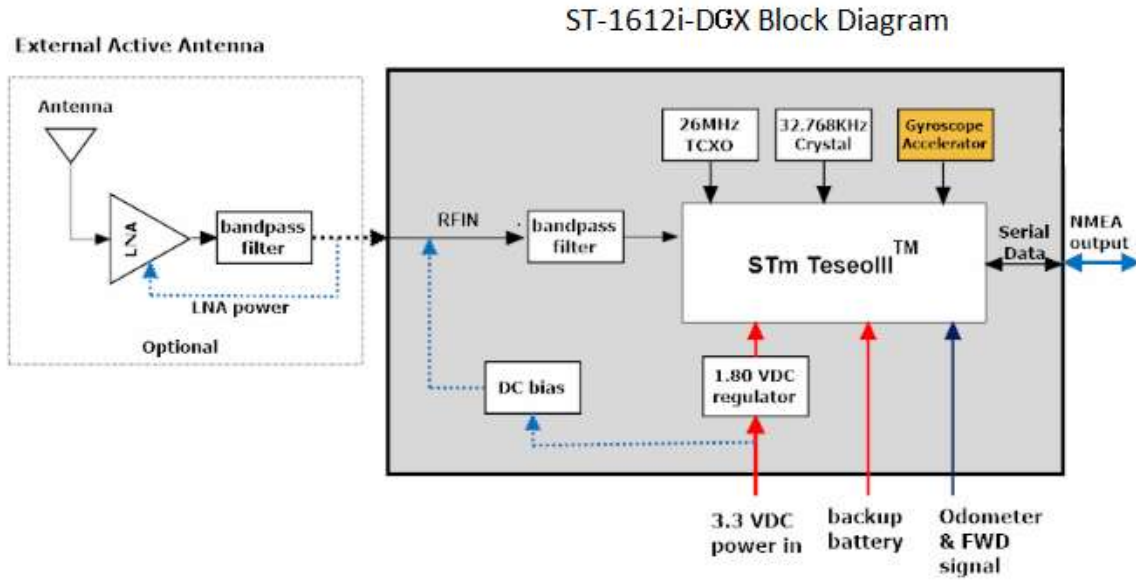

Fig 3-1 System block diagram.

4 GNSS receiver

4.1 GNSS receiver

Chip	Teseo III Series	
Frequency	GPS, GALILEO, QZSS: L1 1575.42MHz, C/A code GLONASS: L1 1598.0625MHz ~ 1605.375MHz, C/A code	
Channels	Support 48 channels	
Update rate	1Hz default	
Sensitivity	Tracking ⁽¹⁾	-163dBm
	Cold start ⁽²⁾	-147dBm
Acquisition Time	Cold Start (Open Sky)	32s (typical)
	Hot Start (Open Sky)	1s (typical)
Position Accuracy	Autonomous	1.8m CEP
	SBAS	1.5m (depends on accuracy of correction data)
Max. Altitude	< 18,000 m	
Max. Velocity	< 515 m/s	
Protocol Support	NMEA 0183 ver 3.01	115200 bps ⁽³⁾ , 8 data bits, no parity, 1 stop bits (default)
		1Hz ⁽⁴⁾ : GGA, GLL, GSA, GSV, RMC, VTG, ZDA

Note1: For signal tracking sensitivity. With a good external LNA (Noise figure <=1.0dB, Gain>=13dB).

Note2: With a good external LNA (Noise figure <=1.0dB, Gain>=13dB).

Note3: Both baud rate and output message rate are configurable to be factory default.

Note4: If needs changes update rate and NMEA sentence, please consult us.

4.2 MEMS Sensor

The ST-1612i-DGX receiver support Dead Reckoning (DR) function, it composed by a 3-axis Gyroscope and 3-axis Accelerometer. To provide optimal solution it needs to calibrate sensor parameters. The sensor parameters are initialized to default values allowing system to start up when no other better information is available, if system is started for the first time in an unknown vehicle gyroscope dedicated maneuvers are required and algorithms able to estimate these parameters.

4.3 Sensor Data Input

The receiver needs two more sensor input, odometer and forward/reverse direction signal.

There are three methods to feed datum to receiver as below descriptions.

- (1) Feed through vehicle Odometer (wheel-tick pulse) input.
- (2) Feed through the UART port; please contact LOCOSYS for more details.
- (3) Feed through CAN Bus (ISO 15765-4).

5 Pin assignment and descriptions

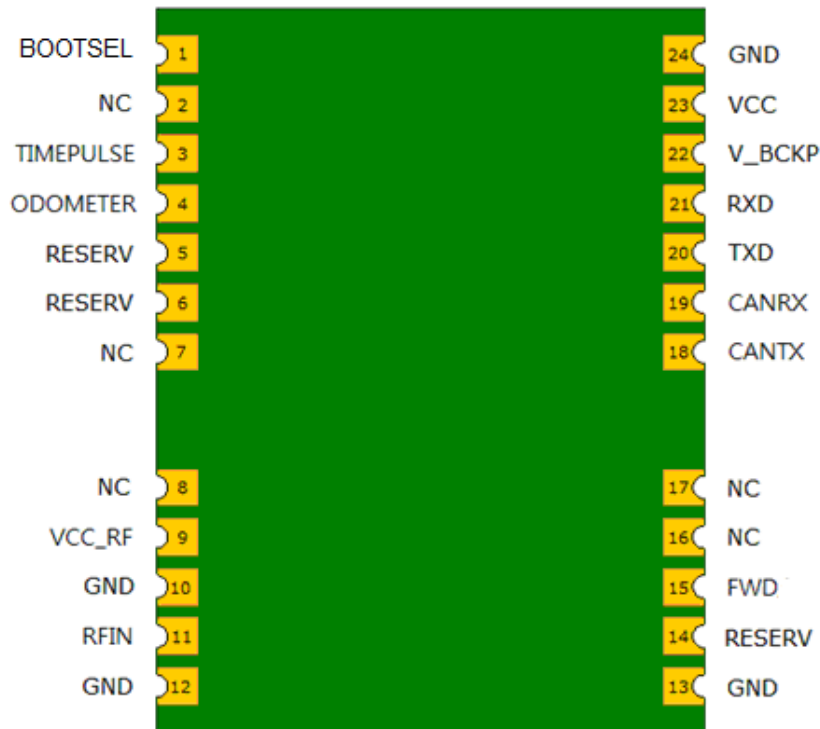

Table 5-1 Pin descriptions Table 5-1 Pin descriptions

Pin #	Name	Type	Description	Note
1	BOOTSEL		For firmware update use only, please keep floating	6
2	NC		Not connected	
3	TIMEPULSE	O	Time pulse (1PPS, default 500 ms pulse/sec, 3.3V Typical)	
4	ODOMETER	I	Odometer wheel-tick input	2
5	RESERV		Reserved, keep floating	
6	RESERV		Reserved, keep floating	
7	NC		Not connected	
8	NC		Not connected	
9	VCC_RF	O	Output voltage for active antenna	1
10	GND	P	Ground	
11	RFIN	I	GNSS RF signal input	
12	GND	P	Ground	
13	GND	P	Ground	
14	RESERV		Reserved, keep floating	
15	FWD	I	Forward/Reverse signal input	2
16	NC		Not connected	

17	NC		Not connected	
18	CANTX	O	CAN bus transmit data output	3
19	CANRX	I	CAN bus receive data input	3
20	TXD	O	UART, asynchronous output (Default NMEA)	
21	RXD	I	UART, asynchronous input	
22	V_BCKP	P	Backup battery supply voltage	4
23	VCC	P	DC supply voltage	5
24	GND	P	Ground	

Note1: The VCC_RF pin short-circuit protection is built-in the module.

Note2: Pin4 and Pin15 need external level shift circuits to meet DC electrical characteristics.

Note3: Need an external CAN Bus Transceiver (Maxim MAX3051, STM L9616D...etc) and vehicle CAN Bus protocol.

Note4: In order to stabilize the V_BACKP power supply, placement of 10uF and 0.1uF capacitor is required to be close to the module.

Note5: The module is operated in fully functions, if customer want to turn module off for power saving reason, please add a PMOS or LDO (with enable pin) to control the module on or off.

Note6: If needs update firmware, please pull high into boot mode, else keep floating.

6 DC & Temperature characteristics

6.1 Absolute maximum ratings

Parameter	Symbol	Ratings	Units
Input Voltage	VCC	3.6	V
Input Backup Battery Voltage	V_BCKP	3.6	V
Operating Temperature Range	Topr	-40 ~ 85	°C
Storage Temperature Range	Tstg	-40 ~ 85	°C

6.2 DC Electrical characteristics

Parameter	Symbol	Conditions	Min.	Typ.	Max.	Units
Input Voltage	VCC		3.0	3.3	3.6	V
Input Backup Battery Voltage	V_BCKP		1.8		3.6	V
VCC_RF Output Voltage	VCC_RF			VCC		V
Supply Current	I _{ss}	VCC = 3.3V, w/o active antenna, Peak			284	mA
		Acquisition		71		mA
		Tracking		68 ⁽¹⁾		mA
Backup Battery Current	I _{bat}	VCC = 0V		37		uA
VCC_RF Output Current	I _{out}	VIN = 3.3V			25	mA
High Level Input Voltage	V _{IH}		2.0		3.6	V
Low Level Input Voltage	V _{IL}		-0.3		0.8	V
High Level Output Voltage	V _{OH}		2.6			V
Low Level Output Voltage	V _{OL}				0.4	V

Note1: Measured when position fix (1Hz) is available and input voltage is 3.3V with UART interface.

6.3 Temperature characteristics

Parameter	Symbol	Min.	Typ.	Max.	Units
Operating Temperature	Topr	-40	-	85	°C
Storage Temperature	Tstg	-40	25	85	°C

7 Mechanical specification

7.1 Recommended Mounting

Please refer to the following figure to mount ST-1612i-DGX on vehicle. The module should be securely mounted to a stable part of the vehicle.

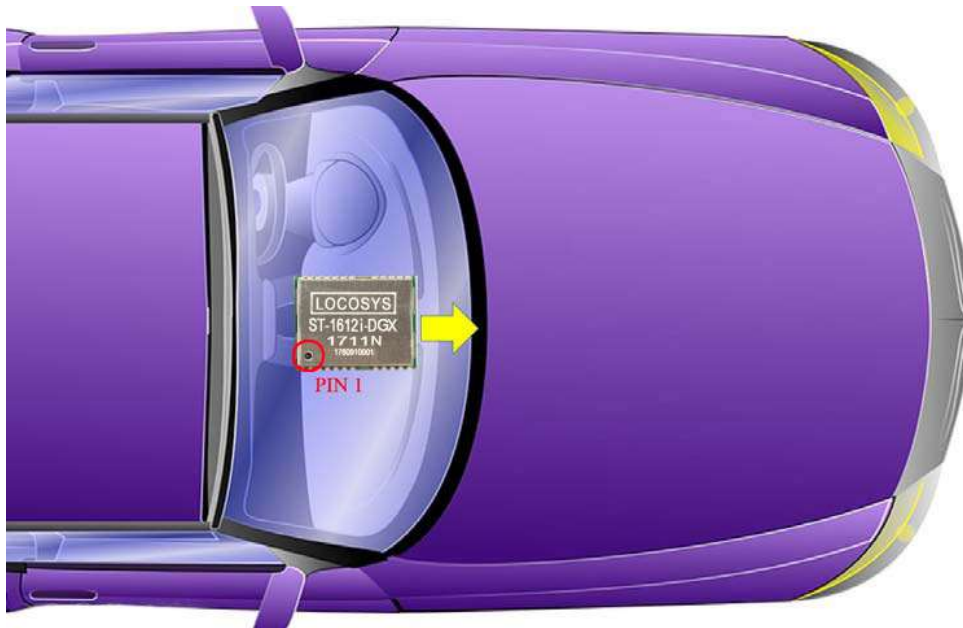

Note1: ST-1612i-DGX module MUST mount horizontally on vehicle (when the vehicle is on a level surface) and toward the front of vehicle. (Default is standard installation method)

Note2: If the module is not mounted as the above figure, please consult LOCOSYS in advance.

7.2 Outline dimensions

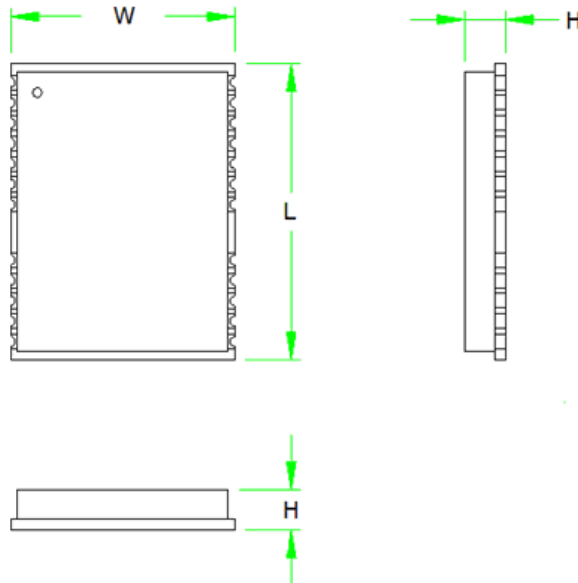

Symbol	Min. (mm)	Typ. (mm)	Max. (mm)
W	12.1	12.2	12.3
L	15.7	16.0	16.4
H	2.1	2.3	2.5

7.3 Recommended land pattern dimensions

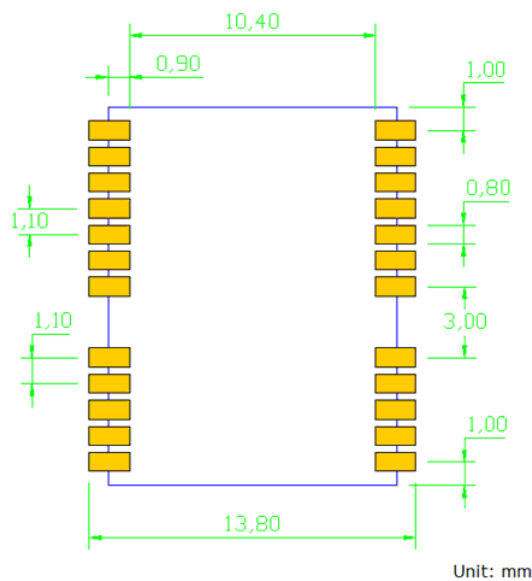

Note: The recommended land pattern dimensions are shown for reference only, as actual pad layouts may vary depending on application.

8 Software interface

8.1 NMEA output message

Table 8.1-1 NMEA output message

NMEA record	Description
GGA	Global positioning system fixed data
GLL	Geographic position - latitude/longitude
GSA	GNSS DOP and active satellites
GSV	GNSS satellites in view
RMC	Recommended minimum specific GNSS data
VTG	Course over ground and ground speed
ZDA	UTC, day, month and year.

- **GGA--- Global Positioning System Fixed Data**

Table 8.1-2 contains the values for the following example:

\$GNGGA,013654.000,2503.71447,N,12138.74593,E,1,16,0.7,130.00,M,15.3,M,,*72

Table 8.1- 2 GGA Data Format

Name	Example	Units	Description
Message ID	\$GNGGA		GGA protocol header
UTC Time	013654.000		hhmmss.sss
Latitude	2503.71447		ddmm.mmmmm
N/S indicator	N		Latitude Direction: North or South
Longitude	12138.74593		dddmm.mmmmm
E/W Indicator	E		Longitude Direction: East or West
Position Fix Indicator	1		See Table 8.1-3
Satellites Used	16		Satellites in use
HDOP	0.7		Horizontal Dilution of Precision,max:99.0
MSL Altitude	130.00	meters	Height above mean sea level
Units	M	meters	Reference Unit for Altitude (“M” = meters)
Geoidal Separation	15.3	meters	Geoidal Separation measure in “M” = meters
Units	M	meters	Reference Unit for Geoidal Separation (“M” = meters)
DGPS Age			Not supported
DGPS Reference			Not supported
Checksum	*72		
<CR> <LF>			End of message termination

Table 8.1-3 Position Fix Indicators

Value	Description
0	Fix not available or invalid
1	GNSS fix valid
2	Differential GNSS fix valid
3-5	Not supported
6	Estimated (Dead Reckoning) Mode

- **GLL--- Geographic Position – Latitude/Longitude**

Table 8.1-4 contains the values for the following example:

\$GNGLL,2503.71447,N,12138.74593,E,013654.000,A,A*42

Table 8.1-4 GLL Data Format

Name	Example	Units	Description
Message ID	\$GNGLL		GLL protocol header
Latitude	2503.71447		ddmm.mmmmm
N/S indicator	N		Latitude Direction: North or South
Longitude	12138.74593		dddmm.mmmmm
E/W indicator	E		Longitude Direction: East or West
UTC Time	013654.000		hhmmss.sss
Status	A		Validity of Data; A=data valid or V=data invalid
Mode	A		A = Autonomous mode, D = Differential mode, E = Estimated (Dead Reckoning) Mode, N=Data invalid,
Checksum	*42		
<CR> <LF>			End of message termination

- **GSA---GNSS DOP and Active Satellites**

Table 8.1-5 contains the values for the following example:

\$GNGSA,A,3,05,24,15,21,10,18,13,12,20,32,,1.1,0.7,0.9*2C

\$GNGSA,A,3,70,69,84,85,68,,,,,,,,,1.1,0.7,0.9*25

\$GNGSA,A,3,193,,,,,,,,,,,,,1.1,0.7,0.9*19

\$GNGSA,A,3,,,,,,,,,,,,,1.1,0.7,0.9*22

\$GNGSA,A,3,,,,,,,,,,,,,1.1,0.7,0.9*22

Table 8.1-5 GSA Data Format

Name	Example	Units	Description
Message ID	\$GNGSA		GSA protocol header
Mode 1	A		See Table 8.1-6

Mode 2	3		See Table 8.1-7
ID of satellite used	05		Sv on Channel 1
ID of satellite used	24		Sv on Channel 2
....		
ID of satellite used			Sv on Channel 12
PDOP	1.1		Position Dilution of Precision,max:99.0
HDOP	0.7		Horizontal Dilution of Precision, max:99.0
VDOP	0.9		Vertical Dilution of Precision, max:99.0
Checksum	*2C		
<CR> <LF>			End of message termination

Table 8.1-6 Mode 1

Value	Description
M	Manual: forced to operate in 2D or 3D mode
A	Automatic: allowed to automatically switch 2D/3D

Table 8.1-7 Mode 2

Value	Description
1	No Fix available
2	2D
3	3D

- **GSV---GNSS Satellites in View**

Table 8.1-8 contains the values for the following example:

```
$GNGSV,6,1,24,03,71,305,46,05,51,197,,11,08,327,45,15,18,289,*68
$GNGSV,6,2,24,16,35,215,45,18,68,103,,19,32,133,,25,23,012,*6B
$GNGSV,6,3,24,30,25,179,45,31,30,139,46,32,34,290,,74,17,006,44*68
$GNGSV,6,4,24,65,41,320,45,76,41,320,45,76,38,265,,75,45,311,*6A
$GNGSV,6,5,24,69,41,320,,70,24,142,,86,09,193,,80,41,320,*6F
$GNGSV,6,6,24,70,08,144,,85,11,142,44,71,56,108,44,72,47,004,43*6C
```

Table 8.1-8 GSV Data Format

Name	Example	Units	Description
Message ID	\$GNGSV		GSV protocol header
Total number of messages ¹	6		Range 1 to 8
Message number ¹	1		Range 1 to 8
Satellites in view	24		Total Number of Satellites in view
Satellite ID	03		Channel 1 (Range 01 to 330)

Elevation	71	degrees	Channel 1 (Range 00 to 90)
Azimuth	305	degrees	Channel 1 (Range 000 to 359)
SNR (C/No)	46	dB-Hz	Channel 1 (Range 00 to 99, null when not tracking)
.....		
Satellite ID	15		Channel 4 (Range 01 to 330)
Elevation	18	degrees	Channel 4 (Range 00 to 90)
Azimuth	289	degrees	Channel 4 (Range 000 to 359)
SNR (C/No)		dB-Hz	Channel 4 (Range 00 to 99, null when not tracking)
Checksum	*68		
<CR> <LF>			End of message termination

Note1: Depending on the number of satellites tracked multiple messages of GSV data may be required.

Note2: GPS ID: 01~32, SBAS ID: 33~51, QZSS ID: 183~197, GLONASS ID: 65~92, GALILEO ID:301~330

- **RMC---Recommended Minimum Specific GNSS Data**

Table 8.1-9 contains the values for the following example:

\$GNRMC,015924.000,A,2503.71417,N,12138.74623,E,0.1,0.0,230217,,D*77

Table 8.1-9 RMC Data Format

Name	Example	Units	Description
Message ID	\$GNRMC		RMC protocol header
UTC Time	015924.000		hhmmss.sss
Status	A		A=data valid or V=data invalid
Latitude	2503.71417		ddmm.mmmmm
N/S Indicator	N		Latitude Direction: North or South
Longitude	12138.74623		dddmm.mmmmm
E/W Indicator	E		Longitude Direction: East or West
Speed over ground	0.1	knots	Speed over ground in knots
Course over ground	0.0	degrees	Course made good,max
Date	230217		ddmmyy
Magnetic variation		degrees	
Variation sense			Magnetic Variation Direction: East or West
Mode	D		A = Autonomous mode, D = Differential mode, E = Estimated (Dead Reckoning) mode, N=Data invalid
Checksum	*77		
<CR> <LF>			End of message termination

- **VTG---Course Over Ground and Ground Speed**

Table 8.1-10 contains the values for the following example:

\$GNVTG,0.0,T,,M,0.1,N,0.1,K,D*16

Table 8.1-10 VTG Data Format

Name	Example	Units	Description
Message ID	\$GNVTG		VTG protocol header
Course over ground	0.0	degrees	Reference to “true” earth poles
Reference	T		Indicates “terrestrial”
Course over ground		degrees	Reference to “magnetic” earth poles
Reference	M		Indicates “Magnetic”
Speed over ground	0.1	knots	Speed over ground in knots
Units	N		Indicates “Knots”
Speed over ground	0.1	km/h	Speed over ground in kilometers per hour
Units	K		Indicates “Kilometers per hour”
Mode	D		A = Autonomous mode, D = Differential mode, E = Estimated (Dead Reckoning)mode
Checksum	*16		
<CR> <LF>			End of message termination

- **ZDA---UTC, day, month and year.**

Table 8.1-11 contains the values for the following example:

\$GNZDA,020849.00,23,02,2017,00,00*78

Table 8.1-11 ZDA Data Format

Name	Example	Units	Description
Message ID	\$GNZDA		ZDA protocol header
Timestamp	020849.00		hhmmss.ss
Day	23		Decimal, 2 digits Day of month (01 to 31)
Month	02		Decimal, 2 digits Month (01 to 12)
Year	2017		Decimal, 4 digits Year (1994 - ...)
Local zone hour	00	hour	Local time zone offset from UTC (set to 00)
Local zone minutes	00	minute	Local time zone offset from UTC (set to 00)
Checksum	*78		
<CR> <LF>			End of message termination

8.2 Proprietary NMEA input/output message

Table 8.2-1 The table below summarizes the set of proprietary command sets for the ST-1612i-DGX

Software command	Command descriptions
\$PSTMCOLD<CR><LF>	Perform a Cold start
\$PSTMWARM<CR><LF>	Perform a Warm start
\$PSTMHOT<CR><LF>	Perform a Hot start
\$PSTMSRR<CR><LF>	System Reset
\$PSTMRESTOREPAR<CR><LF>	Restore System Parameters (Factory Settings)
\$PSTMDRGPS	Reports GNSS fix quality metrics.(option)

● \$PSTMCOLD

Perform a COLD start.

Synopsis:

\$PSTMCOLD,<Mask><CR><LF>

Parameter	Format	Description
Mask	Integer	Optional param to invalidate time, position, ephemeris and almanac: 0x1-clear almanac 0x2-clear ephemeris 0x4-clear position 0x8-clear time

Note: If Mask parameter is not used, default is 0xE (clear ephemeris, time and position).

Example:

\$PSTMCOLD,6

● \$PSTMWARM

Perform a WARM start.

Synopsis:

\$PSTMWARM<CR><LF>

Example:

\$PSTMWARM

● \$PSTMHOT

Perform a HOT start.

Synopsis:

\$PSTMHOT<CR><LF>

Example:

\$PSTMHOT

● **\$PSTMSRR**

Executes a system reset. The GNSS firmware is rebooted.

Synopsis:

\$PSTMSRR<CR><LF>

Example:

\$PSTMSRR

● **\$PSTMRESTOREPAR**

Restore the factory setting parameters. The configuration data block stored in NVM, if present, will be invalidated.

Any changed parameter will be lost.

Synopsis:

\$PSTMRESTOREPAR<CR><LF>

Example:

\$PSTMRESTOREPAR

● **\$PSTMDRGPS---Reports GNSS fix quality metrics.**

Table 8.2-2 contains the values for the following example:

\$PSTMDRGPS,25.057296367,121.620466268,-0.00287,-0.02948,1.387,0.688,1.203,6.280,0.023,-0.06335,4.8*50

Table 8.2-2 \$PSTMDRGPS Data Format

Name	Example	Units	Description
Message ID	\$PSTMDRGPS		PSTMDRGPS protocol header
Lat	25.057296367	degrees	Decimal degrees
Lon	121.620466268	degrees	Decimal degrees
Vn	-0.00287	meters/second	Velocity's north vector component,in meters/second
Ve	-0.02948	meters/second	Velocity's east vector component,in meters/second
PDOP	1.387		Position dilution of precision
HDOP	0.688		Horizontal dilution of precision
VDOP	1.203		Vertical dilution of precision
Rms_pos_residual	6.280	meters	Meters
Rms_vel_residual	0.023	meters	Meters
Vv	-0.06335		Velocity's vertical vector component, in meters/second
Height	4.8		Meters
Checksum	*50		
<CR> <LF>			End of message termination

9 Ordering Information

Model	Interface
ST-1612i-DGA	CAN Bus (ISO 15765-4) 11bit , 250k Bit/s
ST-1612i-DGB	CAN Bus (ISO 15765-4) 11bit , 500k Bit/s
ST-1612i-DGC	CAN Bus (ISO 15765-4) 29bit , 250k Bit/s
ST-1612i-DGD	CAN Bus (ISO 15765-4) 29bit , 500k Bit/s
ST-1612i-DGE	CAN Bus (ISO 15765-4) 11bit , 125k Bit/s
ST-1612i-DGO	Odometer signal input
ST-1612i-DGU	Sensor data over UART input

10 Recommended soldering reflow profile

The module belongs to RoHS device. The maximum of reflow temperature, real on top of PCB, is not over 240 Celsius.

Lead-free Processes

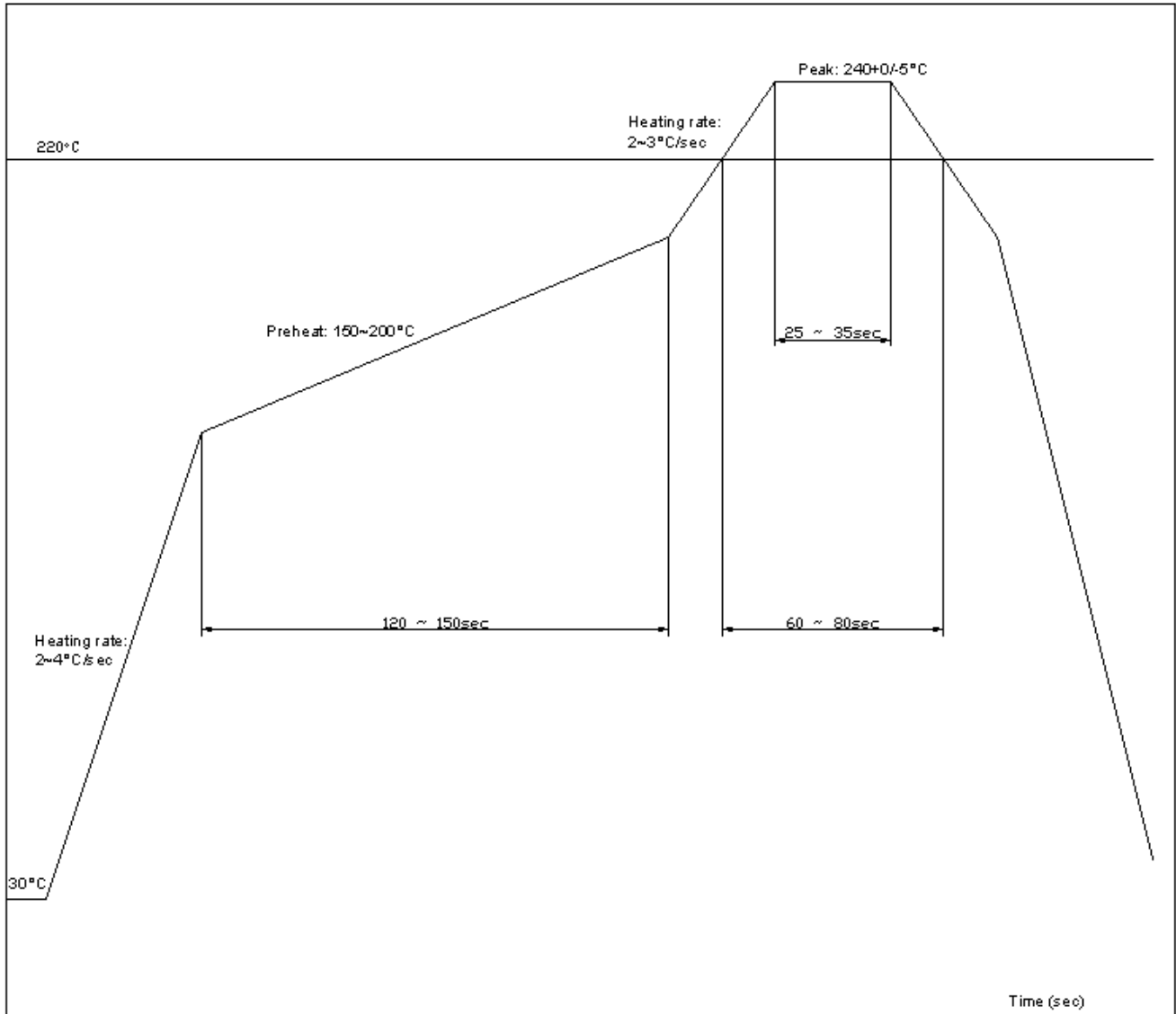

Lead-Free Solder Paste (Sn 96.5-Ag 3.0-Cu 0.5)

Cycle Interval: 300 sec

Note: The ST-1612i-DGX module should be soldered on the topside in the soldering process to prevent from falling down.

11 Reel Packing information

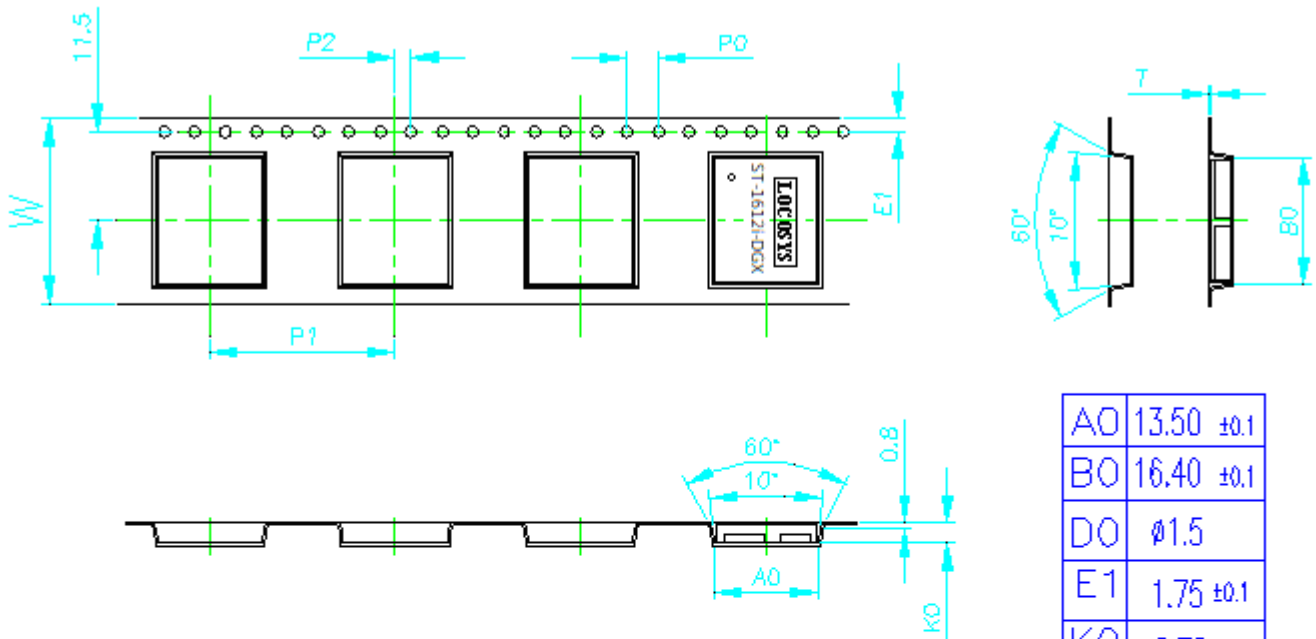

A0	13.50 ±0.1
B0	16.40 ±0.1
D0	∅1.5
E1	1.75 ±0.1
K0	2.70 ±0.1
P0	4.0 ±0.1
P1	24.00 ±0.1
P2	2.0 ±0.10
T	0.3 ±0.10
W	24.0 ±0.30

1. 10 sprocket hole pitch cumulative tolerance ±0.2
2. Camber not to exceed 1mm in 100mm
3. A0 and B0 measured on a plane 0.3mm above the bottom of the pocket
4. K0 measured from a plane on the inside bottom of the pocket to the top surface of the carrier .
5. pocket position relative to sprocket hole measured as true position of pocket,not pocket hole.
6. Component load per 13"reel: 1000 pcs
7. Packing length per 22"reel: 75 M

12 Packing and Handling

GNSS modules, like any other SMD devices, are sensitive to moisture, electrostatic discharge, and temperature. By following the description sketched in the document for LOCOSYS GNSS module storage and handling, it is possible to reduce the chances of them being damaged during production.

12.1 Packing

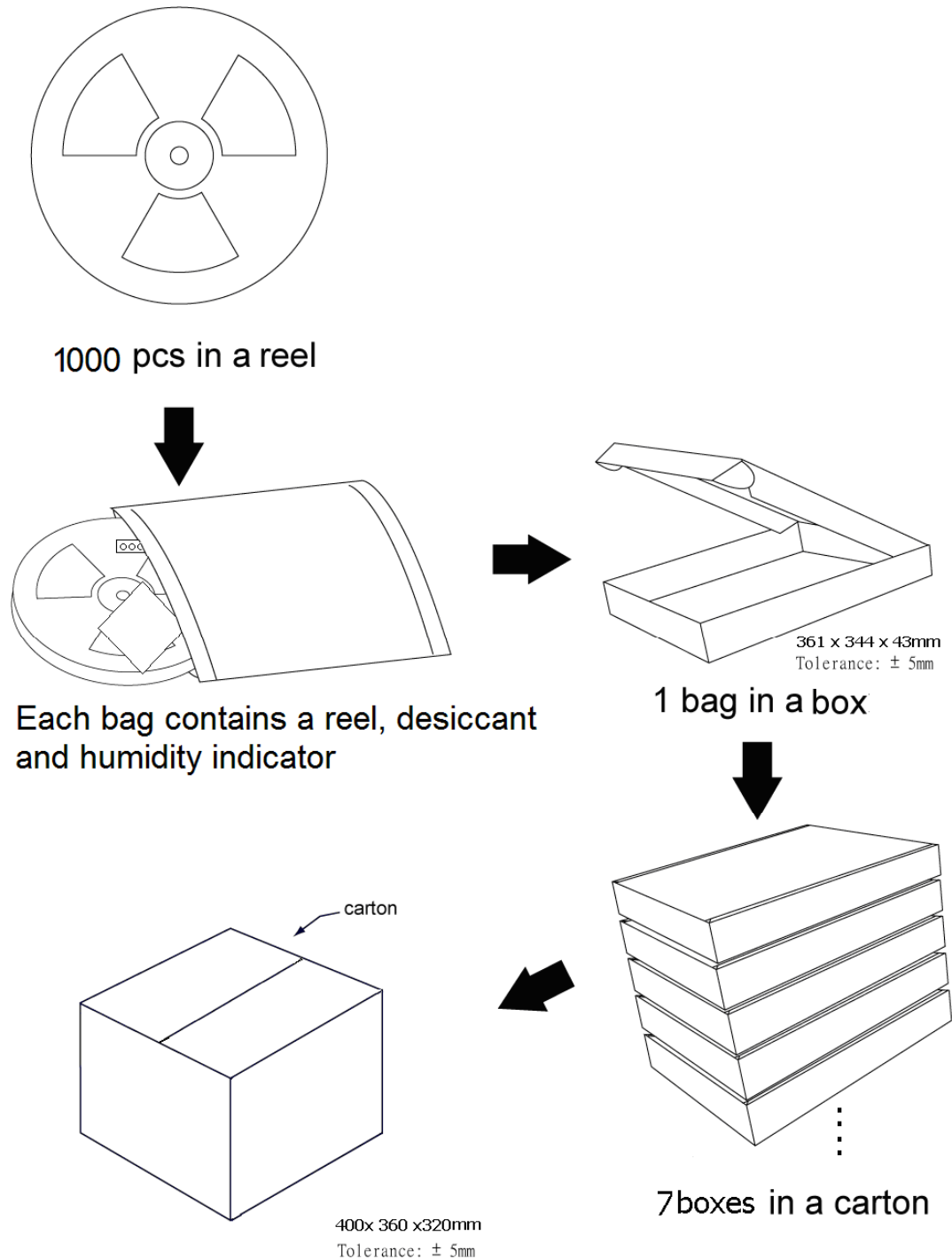

12.2 Moisture Sensitivity

The module belongs to moisture sensitive device (IPC/JEDEC J-STD-020C Level III). If it is not used by then, we strong recommended storing the GNSS modules in dry places such as dry cabinet. The approximate shelf life for LOCOSYS GNSS modules packages is 6 months from the bag seal date, when store in a non-condensing storage environment (<30°C/60% RH)

12.3 ESD Handling



Please carefully follow the following precautions to prevent severe damage to GNSS modules.

LOCOSYS GNSS modules are sensitive to electrostatic discharges, and thus are Electrostatic Sensitive Devices (ESD). Careful handling of the GNSS modules and in particular RFIN pin must follow the standard ESD safety protections:

- Unless there is a galvanic coupling between the local GND and the PCB GND, then the first point of contact when handling the PCB shall always be between the local GND and PCB GND.
- Before working with RFIN pin, please make sure the GND is connected.
- When working with RFIN pin, do not contact any charges capacitors or materials that can easily develop or store charges such as patch antenna, coax cable, soldering iron.
- When soldering RFIN pin, please make sure to use an ESD safe soldering iron (tip).

13.2 For CAN Bus Reference

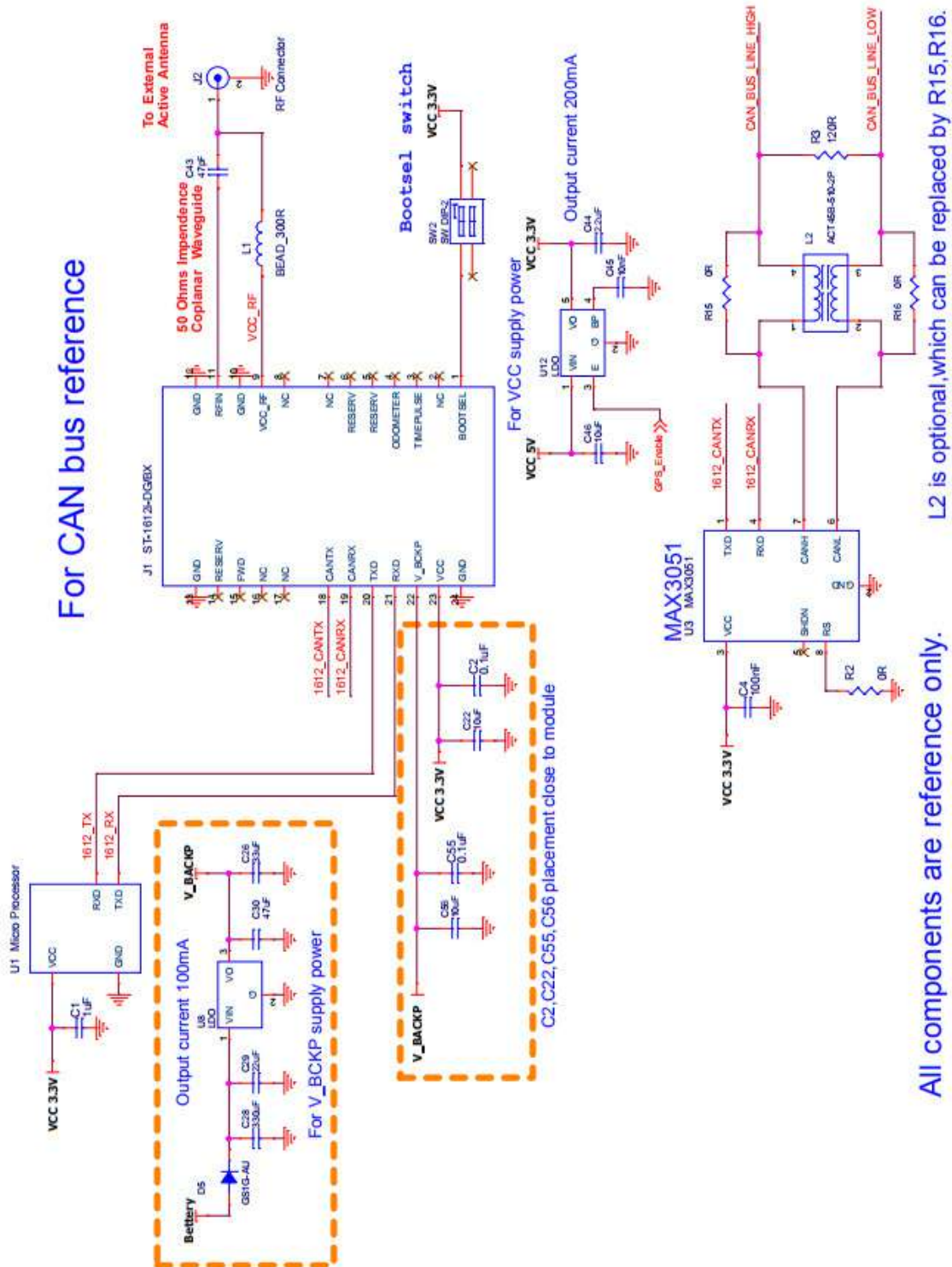

13.3 For UART input Reference

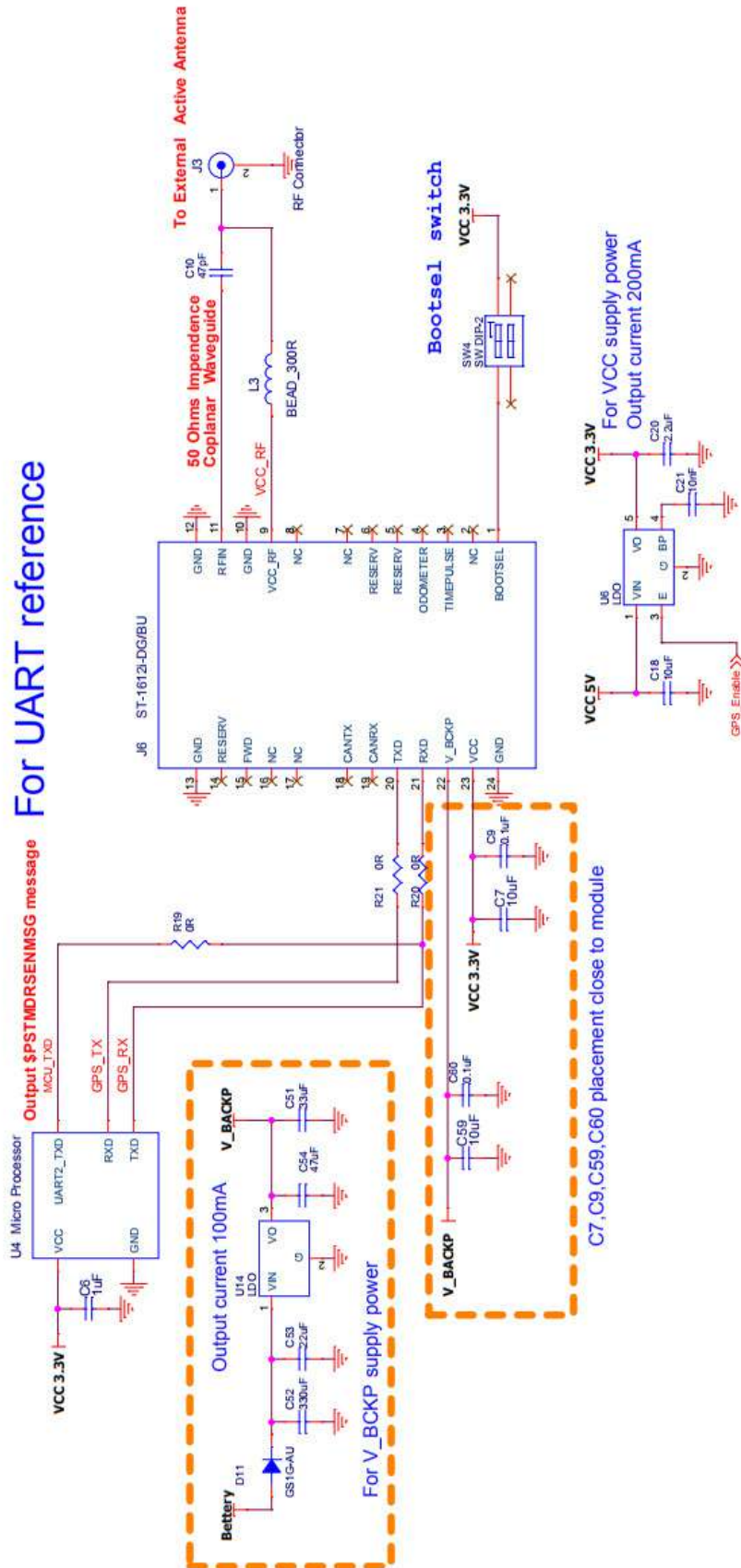

All components are reference only.

Document change list

Revision 1.0

- First release on Feb.26.2018

Revision 1.1 (Aug.03.2018)

- Remove Support tow alert on page 1.
- Remove interrupt signal from system block diagram on page 2.
- Remove Pin 2 interrupt signal on page 4.
- Modify Backup Battery Current on page 6.
- Remove interrupt signal from reference circuit on page 20 ~ 22.

Revision 1.2 (Dec.10.2018)

- Add AEC-Q100 qualified for automotive grade on page 1.

Revision 1.3 (Jan.14.2019)

- Modify product's appearance photo on page 1.
- Add standard specifies for SAE J2945/1 on page 1.
- Modify Supply Current - Tracking and Backup Battery Current on page 6.
- Modify Recommended Mounting photo on page 7.

Revision 1.4 (Mar.15.2019)

- Modify pin1 description on page 4 ~ 5.
- Modify reference circuit on page 20 ~ 22.

Revision 1.5 (May.03.2019)

- Modify introduction and features on page 1.
- Modify Protocol Support on page 3.
- Add proprietary output sentence on page 14 ~ 15.