

Product name	Description	Version
RTK-4671-MHPD	Dual-frequency and dual-antenna RTK receiver	0.2



## 1. Introduction

LOCOSYS RTK-4671-MHPD is a dual-frequency, dual-antenna receiver targeting for precision agriculture, drones, and slow-moving vehicles. This receiver provides fast precise heading and RTK position. It supports multiple constellations, including GPS, GLONASS, BeiDou, GALILEO, QZSS and SBAS to improve the continuity and reliability of precise heading and RTK position even in the harsh environment. Besides, it features powerful compatibility with other GNSS receivers in the market by flexible interfaces, smart hardware design and popular log/command formats.

Versatile, compact, smart, low power and high update rate, LOCOSYS RTK-4671-MHPD meets the requirement of most location-based applications.

## 2. Features

- Dual-frequency and multi-constellation heading and RTK positioning solution
- Dual 64 channels GNSS with dual-antenna input
- Built in independent short-circuit protection for each antenna input
- Heading accuracy < 0.2° RMS
- Up to 5 Hz update rate
- Industrial operating temperature range -40 to +85°C
- Low-power consumption and compact size
- Easy and simply to integrate
- LOCOSYS IATF 16949 certified production sites.

## 3. Application

- Autonomous Vehicle Guidance
- Unmanned Aerial Vehicles
- Precision Agriculture

- AGV Robotics
- V2X / ETC / 5G Station
- Structural / Land Monitoring
- Offshore / Marine Application

#### 4. Product feature

GNSS feature	Description	
GNSS	Dual frequency and Multi-constellation	
DGPS, SBAS	WAAS, EGNOS, MSAS	
Channels	64 channels	
Update rate	1(default), 2, or 5 Hz	
Acquisition Time <sup>1</sup>	Cold start	32s (typical)
	Convergence time	< 10s (typical; after 3D fix)
Position Accuracy <sup>1,2</sup>	Autonomous	< 1.5m CEP
	SBAS	< 1.5m (depends on accuracy of correction data)
	RTK <sup>3</sup>	0.01m + 1ppm
Heading Accuracy	< 0.2 deg @ 1m antenna separation (RMS)	
Limitations	Max. Altitude	< 18,000 m, up to 50,000m by request
	Max. Velocity	< 515 m/s
Navigation Outputs	NMEA 0183 ver. 4.0	115200 bps, 8 data bits, no parity, 1 stop bit (default) 1Hz: GGA, GSA, RMC, HDT 0.2Hz: GSV
Correction Input <sup>4</sup>	RTCM-3.3	115200 bps, 8 data bits, no parity, 1 stop bits

Note 1: Acquisition time and position accuracy may be affected by atmospheric conditions, signal multipath, satellite geometry and corrections availability and quality.

Note 2: All position values are based on Horizontal position accuracy.

Note 3: RMS, 24hr static.

Note 4: Supported RTCM data message see page 5.

## 5. Block diagram

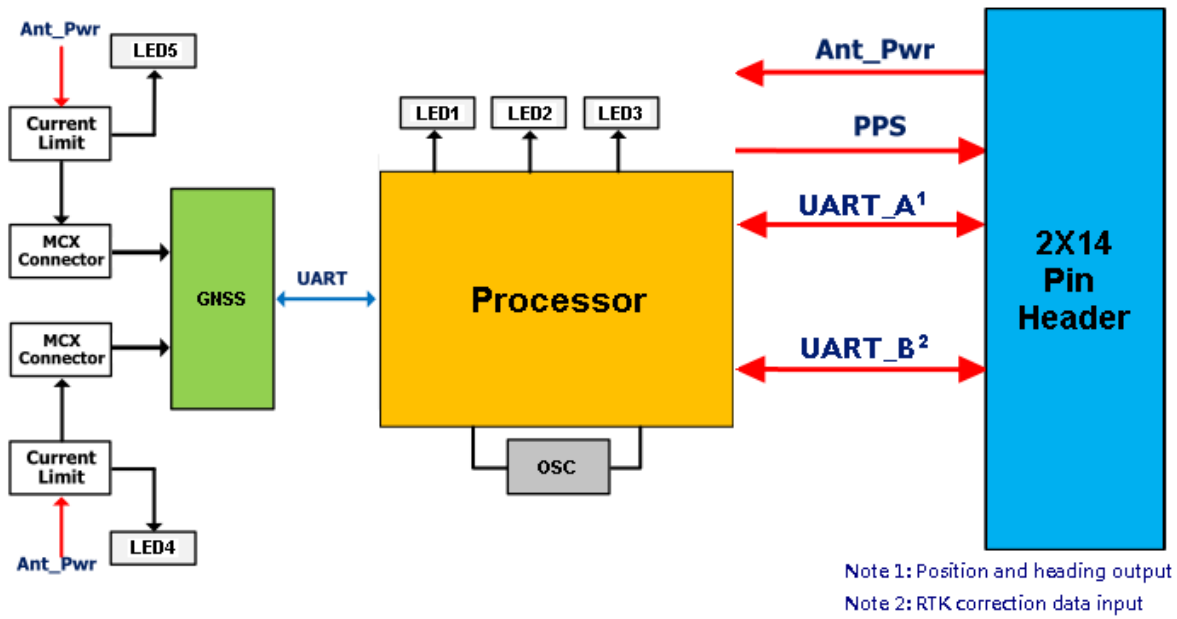

## 6. Pin definition

### 6.1. Pin assignment

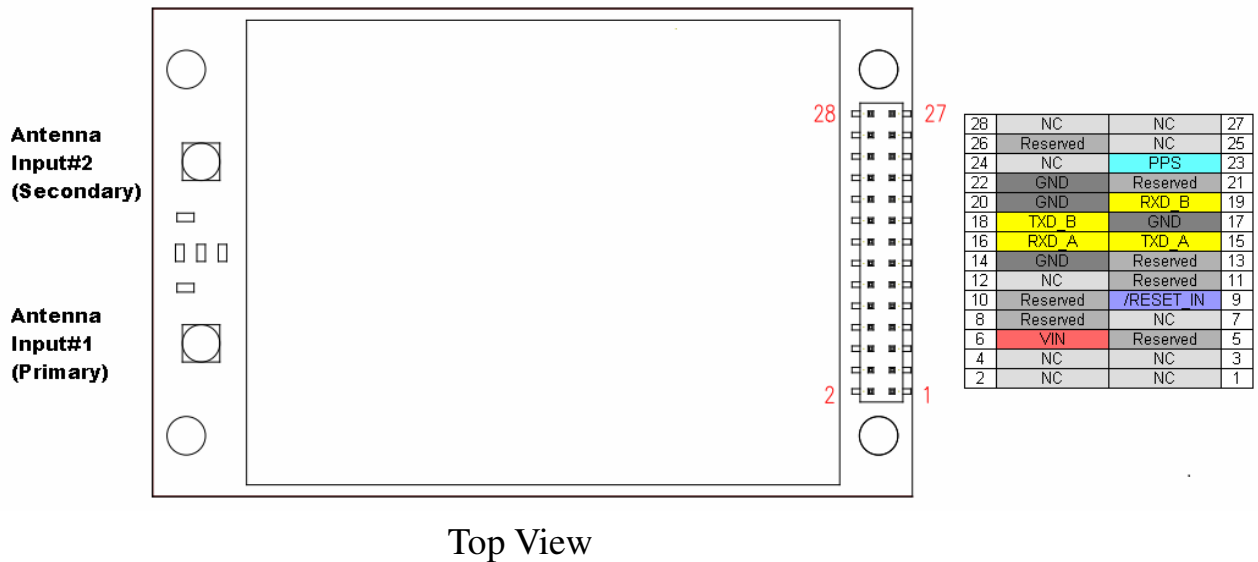

## 6.2. Pin description

Pin No	Name	Description
1	NC	Not connected
2	NC	Not connected
3	NC	Not connected
4	NC	Not connected
5	Reserved	Microprocessor BOOT pin, this pin should be left floating
6	VIN	Device power supply
7	NC	Not connected
8	Reserved	Reserved, this pin should be left floating
9	RESET_IN	Device reset input, Low active
10	Reserved	Reserved, this pin should be left floating
11	Reserved	Reserved, this pin should be left floating
12	NC	Not connected
13	Reserved	Reserved, this pin should be left floating
14	GND	Ground
15	TXD_A	UART_A, transmitter output (Default NMEA)
16	RXD_A	UART_A, receiver input (Default NMEA)
17	GND	Ground
18	TXD_B	<b>UART_B transmitter output</b>
19	RXD_B	<b>UART_B receiver input, receive RTCM data streaming from base station to resolve RTK solutions.</b>
20	GND	Ground
21	Reserved	Reserved, this pin should be left floating
22	GND	Ground
23	PPS	Time pulse (1PPS, default 100 ms pulse/sec when 3D fix is available)
24	NC	Not connected
25	NC	Not connected
26	Reserved	Reserved, this pin should be left floating
27	NC	Not connected
28	NC	Not connected

## 7. Data Interfaces and Protocols

### 7.1. Data Interface

The RTK-4671-MHPD receiver features 28 (2x14) pin header 2.0mm pitch (male) for connection to host system. It have two UART interfaces are available, and the baud rate for communication is 115200 bps.

### 7.2. Device Configuration

The RTK-4671-MHPD interfaces are support the following communication protocols:

UART_A	NMEA, 115200 bps. (GGA, GSA, RMC, GSV, HDT)	Position and heading output
UART_B	TX: NMEA, 115200 bps. (GGA) RX: RTCM-3.3, 115200 bps. See “Supported Data Messages” table.	RTK correction data input

Supported Data Messages:

Message Type	Description
1005	Stationary RTK reference station ARP
1006	Stationary RTK reference station ARP with antenna height
1019	GPS ephemeris data
1042	BeiDou ephemeris data
1074	Full GPS Pseudoranges and PhaseRanges plus CNR
1075	Full GPS Pseudoranges, PhaseRanges, PhaseRangeRate and CNR
1077	Full GPS Pseudoranges, PhaseRanges, PhaseRangeRate and CNR (high resolution)
1124	Full BeiDou Pseudoranges and PhaseRanges plus CNR
1125	Full BeiDou Pseudoranges, PhaseRanges, PhaseRangeRate and CNR
1127	Full BeiDou Pseudoranges, PhaseRanges, PhaseRangeRate and CNR (high resolution)

### 8. GNSS antenna setup for heading measure

The receiver is always configured to provide precise heading when both antennas are connected and have a clear view of the sky. The Heading is alignment of two antennas from “Antenna Input # 1” to “Antenna Input #2”, and it is relative to True North. As shown in the diagram below:

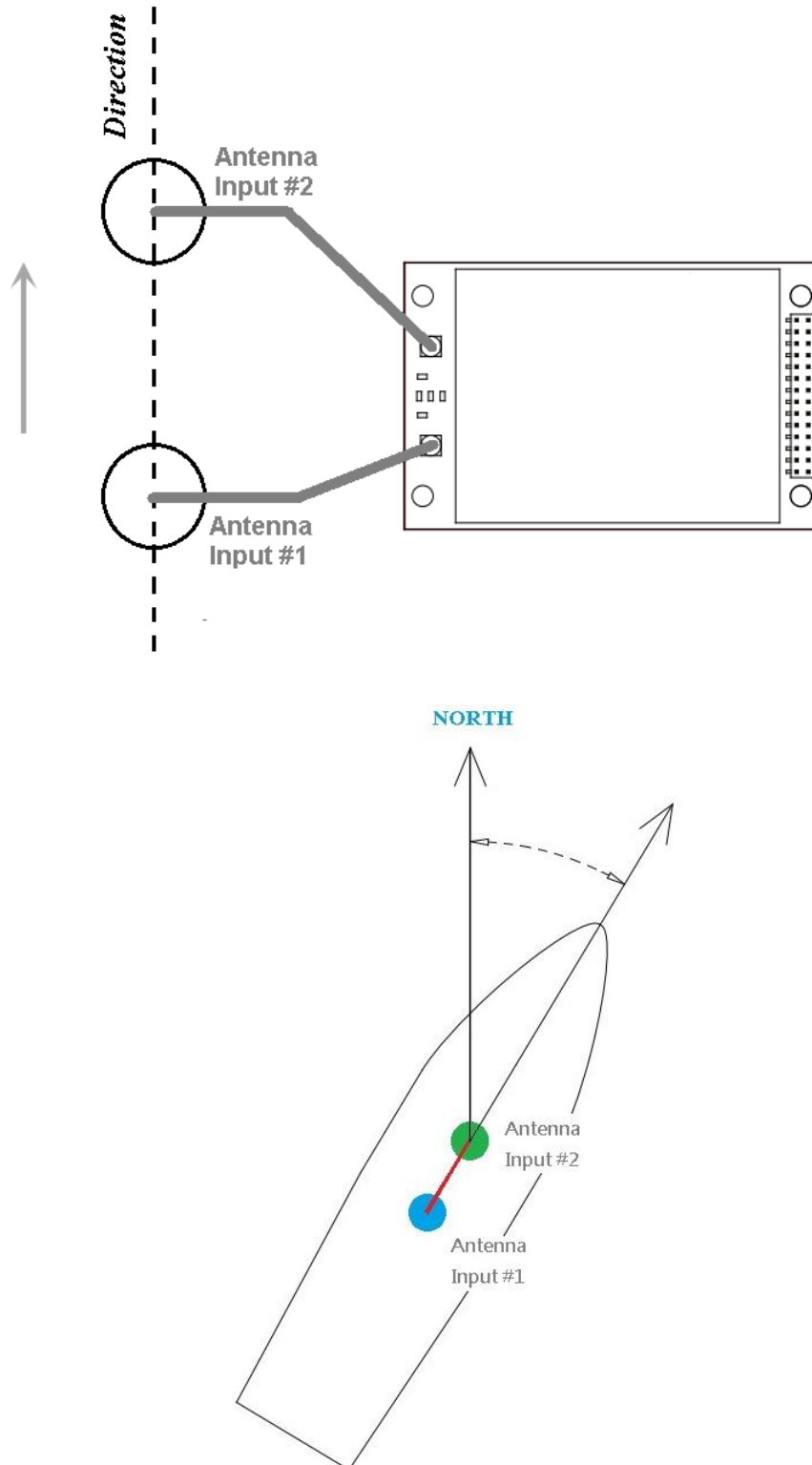

## 9. Electrical specifications

### 9.1. DC Electrical Characteristics

Parameter	Symbol	Conditions	Min.	Typ.	Max.	Units
Input voltage	VCC		3.2	3.3	4.5	V
External Active Antenna Output Voltage Current	ANT_PWR _OUT			3.3 200		V mA
Input current	Icc	VCC = 3.3V, w/o active antenna, Peak Tracking		325	470	mA mA
High Level Input Voltage	V <sub>IH</sub>		2.1		3.6	V
Low Level Input Voltage	V <sub>IL</sub>				0.8	V
High Level Output Voltage	V <sub>OH</sub>		2.4			V
Low Level Output Voltage	V <sub>OL</sub>				0.4	V

### 9.2. Temperature characteristics

Parameter	Symbol	Min.	Typ.	Max.	Units
Operating Temperature	Topr	-40	-	85	°C
Storage Temperature	Tstg	-40	-	85	°C

10. Board Layout and Dimensions

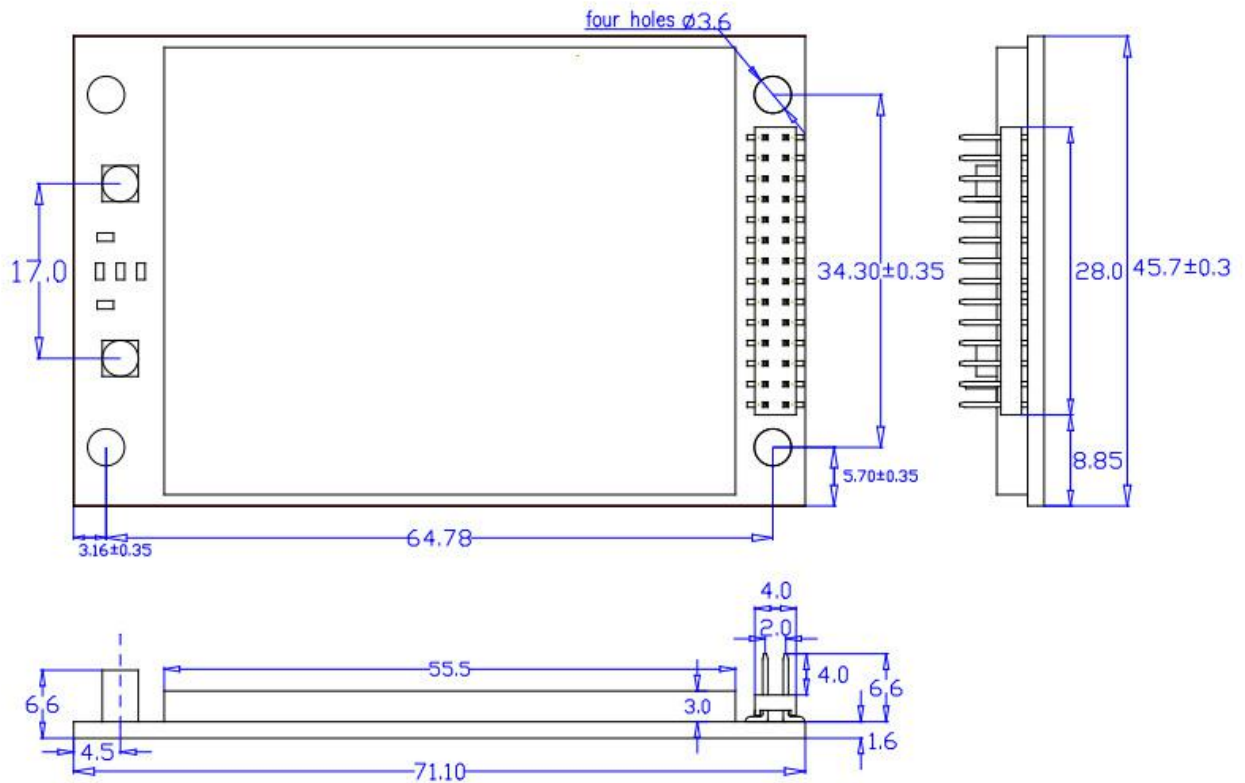

unit: mm  
 Tolerance: ±0.2  
 Weight: 24g

11. LED indicator

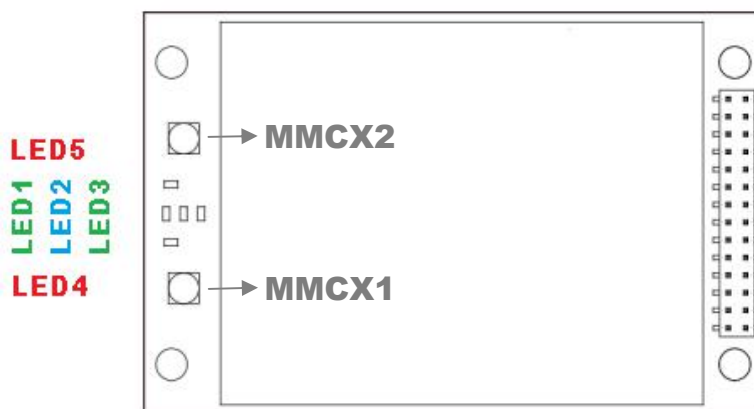

LED1 flash (Green LED, 1Hz) means the receiver is in precise heading status  
 LED2 flash (Blue LED, 1Hz) means the receiver is normal operation.  
 LED3 flash (Green LED, 1Hz) means the receiver is in RTK FIX mode status  
 LED4 or/and LED5 flash (Red LED) means short-circuit on the MMCX1 or/and MMCX2 active antenna connector.



## 12. Software interface

### 12.1. NMEA output message

Table 12.1-1 NMEA output message

NMEA record	Description
GGA	Global positioning system fixed data
GSA	GNSS DOP and active satellites
GSV	GNSS satellites in view
RMC	Recommended minimum specific GNSS data
HDT	Heading from true north message fields

- **GGA--- Global Positioning System Fixed Data**

Table 12.1-2 contains the values for the following example:

\$GNGGA,021027.000,2503.7125580,N,12138.7454063,E,4,18,0.65,121.422,M,15.3,M,1,\*4D

Table 12.1- 2 GGA Data Format

Name	Example	Units	Description
Message ID	\$GNGGA		GGA protocol header (GNGGA)
UTC Time	021027.000		hhmmss.sss
Latitude	2503.7125580		ddmm.mmmmmmm
N/S indicator	N		N=north or S=south
Longitude	12138.7454063		dddmm.mmmmmmm
E/W Indicator	E		E=east or W=west
Position Fix Indicator	4		See Table 12.1-3
Satellites Used	18		Range 0 to 33
HDOP	0.65		Horizontal Dilution of Precision
MSL Altitude	121.422	meters	
Units	M	meters	
Geoid Separation	15.3	meters	
Units	M	meters	
Age of Diff. Corr.	1	second	Null fields when DGPS is not used
Diff. Ref. Station ID			
Checksum	*4D		

Table 12.1-3 Position Fix Indicators

Value	Description
0	Fix not available or invalid
1	GNSS SPS Mode, fix valid
2	Differential GPS, SPS Mode, fix valid
4	Real-Time Kinematic, fixed integers
6	Dead Reckoning Mode, fix valid

● **GSA---GNSS DOP and Active Satellites**

Table 12.1-4 contains the values for the following example:

\$GPGSA,A,3,23,11,22,28,19,06,09,17,03,01,30,,0.94,0.62,0.71\*06

\$BDGSA,A,3,07,10,04,02,03,06,13,01,,,,,0.94,0.62,0.71\*1A

Table 12.1-4 GSA Data Format

Name	Example	Units	Description
Message ID	\$GPGSA		GSA protocol header
Mode 1	A		See Table 12.1-5
Mode 2	3		See Table 12.1-6
ID of satellite used	23		Sv on Channel 1
ID of satellite used	11		Sv on Channel 2
....			....
ID of satellite used			Sv on Channel 12
PDOP	0.94		Position Dilution of Precision
HDOP	0.62		Horizontal Dilution of Precision
VDOP	0.71		Vertical Dilution of Precision
Checksum	*06		
<CR> <LF>			End of message termination

Table 12.1-5 Mode 1

Value	Description
M	Manual- forced to operate in 2D or 3D mode
A	Automatic-allowed to automatically switch 2D/3D

Table 12.1-6 Mode 2

Value	Description
1	Fix not available
2	2D
3	3D

● **GSV---GNSS Satellites in View**

Table 12.1-7 contains the values for the following example:

```
$GPGSV,4,1,14,03,12,310,35,10,12,177,35,14,77,028,40,16,36,227,39,1*61
$GPGSV,4,2,14,22,21,292,32,25,18,039,34,26,63,252,43,29,31,075,40,1*63
$GPGSV,4,3,14,31,51,358,43,32,62,120,44,193,45,173,38,194,65,031,41,1*63
$GPGSV,4,4,14,195,41,134,38,199,60,167,35,1*65
$GPGSV,4,1,14,03,12,310,,10,12,177,,14,77,028,,16,36,227,,6*68
$GPGSV,4,2,14,22,21,292,,25,18,039,,26,63,252,29,29,31,075,,6*6A
$GPGSV,4,3,14,31,51,358,,32,62,120,33,193,45,173,,194,65,031,32,6*6C
$GPGSV,4,4,14,195,41,134,31,199,60,167,31,6*6F
$GLGSV,2,1,06,65,30,324,36,71,41,174,38,72,70,276,36,73,16,038,36,1*7E
$GLGSV,2,2,06,75,33,282,34,84,13,099,28,1*77
$GLGSV,2,1,06,65,30,324,33,71,41,174,36,72,70,276,36,73,16,038,,3*72
$GLGSV,2,2,06,75,33,282,36,84,13,099,35,3*7B
$GBGSV,5,1,18,01,54,142,41,02,38,240,37,03,57,204,40,04,38,118,37,1*72
$GBGSV,5,2,18,05,15,257,30,06,82,087,42,07,74,278,41,09,65,333,41,1*7F
$GBGSV,5,3,18,10,51,246,38,11,22,084,35,16,83,027,44,20,12,318,36,1*7A
$GBGSV,5,4,18,23,54,348,45,25,26,050,38,28,14,163,34,32,52,276,43,1*73
$GBGSV,5,5,18,34,12,061,37,37,29,280,38,1*76
$GBGSV,5,1,18,01,54,142,40,02,38,240,39,03,57,204,40,04,38,118,36,3*7E
$GBGSV,5,2,18,05,15,257,,06,82,087,40,07,74,278,40,09,65,333,40,3*7C
$GBGSV,5,3,18,10,51,246,37,11,22,084,36,16,83,027,40,20,12,318,,3*75
$GBGSV,5,4,18,23,54,348,,25,26,050,,28,14,163,,32,52,276,,3*7B
$GBGSV,5,5,18,34,12,061,,37,29,280,,3*7B
```

Table 12.1-7 GSV Data Format

Name	Example	Units	Description
Message ID	\$GPGSV		GSV protocol header
Total number of messages <sup>1</sup>	4		Range 1 to 4
Message number <sup>1</sup>	1		Range 1 to 4
Satellites in view	14		
Satellite ID	03		Channel 1 (Range 01 to 196)
Elevation	12	degrees	Channel 1 (Range 00 to 90)
Azimuth	310	degrees	Channel 1 (Range 000 to 359)
SNR (C/No)	35	dB-Hz	Channel 1 (Range 00 to 99, null when not tracking)
....			....
Satellite ID	16		Channel 4 (Range 01 to 196)
Elevation	36	degrees	Channel 4 (Range 00 to 90)
Azimuth	227	degrees	Channel 4 (Range 000 to 359)

SNR (C/No)	39	dB-Hz	Channel 4 (Range 00 to 99, null when not tracking)
SignalId	1		
Checksum	*61		
<CR> <LF>			End of message termination

Note 1: Depending on the number of satellites tracked multiple messages of GSV data may be required.

● **RMC---Recommended Minimum Specific GNSS Data**

Table 12.1-8 contains the values for the following example:

\$GNRMC,021027.000,A,2503.7125580,N,12138.7454063,E,0.01,171.63,030919,,,R\*62

Table 12.1-8 RMC Data Format

Name	Example	Units	Description
Message ID	\$GNRMC		RMC protocol header
UTC Time	021027.000		hhmmss.sss
Status	A		A=data valid or V=data not valid
Latitude	2503.7125580		ddmm.mmmmmmm
N/S Indicator	N		N=north or S=south
Longitude	12138.7454063		dddmm.mmmm
E/W Indicator	E		E=east or W=west
Speed over ground	0.01	knots	True
Course over ground	171.63	degrees	
Date	030919		ddmmyy
Magnetic variation		degrees	
Variation sense			E=east or W=west (Not shown)
Mode	R		A=autonomous, D=DGPS, E=DR, N=Data not valid, R=Coarse Position, S=Simulator
Checksum	*62		
<CR> <LF>			End of message termination

● **HDT---Heading from true north message fields**

Table 12.1-9 contains the values for the following example:

\$GPHDT,40.14,T\*34

Table 12.1-9 GPHDT Data Format

Name	Example	Units	Description
Message ID	\$GPHDT		HDT protocol header
Heading	40.14	degrees	Heading in degrees
Relative to True North	T		Indicates heading relative to True North
Checksum	*34		

<CR> <LF>		End of message termination
-----------	--	----------------------------

## 12.2. LOCOSYS proprietary commands

### 12.2.1. Query firmware version

**Synopsis:**

```
$PLSC,VER*CK<CR><LF>
```

**Response:**

```
$PLSR,<VER>*CK<CR><LF>
```

**Examples:**

```
$PLSC,VER*61<CR><LF>
```

### 12.2.2. Get setting for the two antenna distance;

**Synopsis:**

```
$PLSC,COM4,{PLSC,GETDIST}*CK<CR><LF>
```

**Response:**

```
$PLSR,DIST,<DIST>*CK<CR><LF>
```

Parameter	Format	Description
DIST	Decimal	setting for the two antenna distance (unit: mm); if the value = 0, means antenna distance is not set

**Examples:**

```
$PLSC,COM4,{PLSC,GETDIST}*03<CR><LF>
```

### 12.2.3. Set antenna distance

**Synopsis:**

```
$PLSC,COM4,{PLSC,SETDIST,<DIST>}*CK<CR><LF>
```

**Response:**

```
$PLSR,DIST,<DIST>*CK<CR><LF>
```

Parameter	Format	Description
DIST	Decimal	To set the distance between two antenna

**Examples:**

```
$PLSC,COM4,{PLSC,SETDIST,5001}*0E<CR><LF>
```

Note 1: Set two antenna distance is 500 mm

#### 12.2.4. Set update rate

**Synopsis:**

```
$PLSC,SETMXHZ,<RATE>*CK<CR><LF>
```

**Response:**

```
$PLSR,MXHZ,<RATE>*CK<CR><LF>
```

Parameter	Format	Description
RATE	Decimal	The output data update rate, in Hz.(included 1, 2, or 5 Hz)

**Examples:**

```
$PLSC,SETMXHZ,1*78<CR><LF>
```

#### 12.2.5. Serial port (for receive correction data) setting

**Synopsis:**

```
$PLSC,INJ,<PORT>*CK<CR><LF>
```

**Response:**

```
$PLSR,INJ,<PORT>*CK<CR><LF>
```

Parameter	Format	Description
PORT	Decimal	0: RXD_B (Pin-19) to receive correction data from base station (default) 1: RXD_A (Pin-16) to receive correction data from base station

**Examples:**

```
$PLSC,INJ,1*61<CR><LF>
```

## Document change list

### Revision 0.1

- Draft release on November 20, 2019

### Revision 0.2 (Jan.03.2020)

- Modify section 4 Acquisition Time and Note on page 2.
- Modify section 9.1 Input voltage and current on page 7.
- Modify section 10 product weight on page 8.
- Added LOCOSYS proprietary commands 12.2.5 Serial port (for receive correction data) setting on page 14.