

Product name	Description	Version
MC-1612-DG	Datasheet of MC-1612-DG multiple GNSS module with ADR/UDR auto switch function	0.7



## 1 Introduction

LOCOSYS MC-1612-DG is a single-band multi-system with an ARM base processor. It not only supports GPS, GLONASS, BDS, GALILEO, QZSS and SBAS, but also has a flash memory, TCXO, RTC crystal, LNA and SAW filter, and embedded MEMS sensors (6-axis accelerometers gyros), 1-hole pressure (option) Micro-Electro-Mechanical Systems (MEMS) sensor, equipped with DR software. The extended Kalman filter algorithm combines GNSS and MEMS sensor data with a weighting function that relies on GNSS signal quality. With adverse GNSS conditions in urban canyons, tunnels, or parking garages where DR boosts the accuracy, and the software fills the gaps. It supports three dimensional DR, Standard NMEA output including height, slope ...message output, fully supports various map mapping demand.

ADR modes, MC-1612-DG have high-precision positioning and dead reckoning performance, offers real-time 1.5m accuracy positioning and heading with low-power consumption. The software includes features to receive and use data from the built-in sensors along with external signals for wheel speed and Forward/Reverse direction, the vehicle signals are used to provide a high level of accuracy in the navigation solution. It features high sensitivity, low power and ultra-small form factor, and provide user the superior performance.

UDR mode, MC-1612-DG when under the environment with pool signal like tunnels, urban and under grounder also unable to gain the speed through vehicle, UDR will play the role to keep positioning by the built-in MEMS which means MC-1612-DG keeps to perform the capacity of seamless positioning with UDR where the application at the environment above.

### **Highlight: MC-1612-DG have both GNSS/ADR/UDR | 3-in-1 Seamless Positioning**

MC-1612-DG offers the full-coverage positioning functionalities wherever the poor-signal environment or the installation position and keep to output high positioning performance for your applications might be under harsh environment. In the mean time, your design will be benefited from applying MC-1612-DG, the 3-in-1 solution so that easy to design (You can choose to have physical speed input or not) for saving time and efforts and boost the high positioning performance exceed your expectation.

## 2 Features

- Support GPS, GLONASS, GALILEO, BEIDOU, QZSS
- Capable of SBAS (WAAS, EGNOS, MSAS, GAGAN)
- Built-in LOCOSYS Dead Reckoning (ADR/UDR) both technology software
- Built-in MEMS sensor (3-axis Gyroscope and 3-axis Accelerometer)
- Support MEMS Raw data high update rate (up to 100Hz)
- Built-in pressure sensor (option)
- Fast TTFF at low signal level
- Great anti-jamming performance (due to multi-tone active interference canceller)
- Automatic configuration of wheel-tick/speed input
- Support sensors data feed through the UART port
- Support Odometer (wheel-tick pulse) input
- Support ADR/UDR automatic fast learning calibration
- Small form factor 16 x 12.2 x 2.4 mm
- SMD type, RoHS compliant
- LOCOSYS IATF 16949 quality control

## 3 Application

- Autonomous Vehicle Guidance
- Autonomous Vehicle (ex: AVN/T-BOX/HUD)
- Internet of Vehicles
- Unmanned Aerial Vehicles
- Precision Agriculture
- Hand-Held Device
- AGV Robotics
- V2V / V2X System
- Geographical measurement
- Geographical survey points
- Tracker

4 System Block Diagram

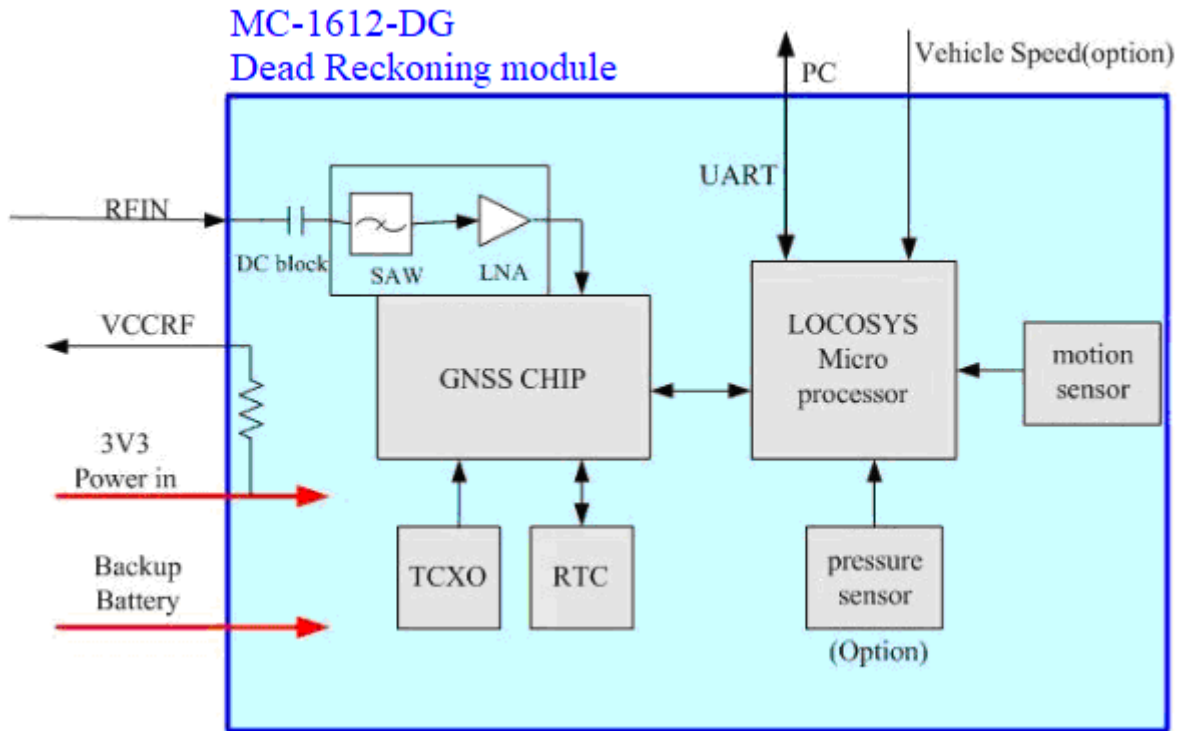
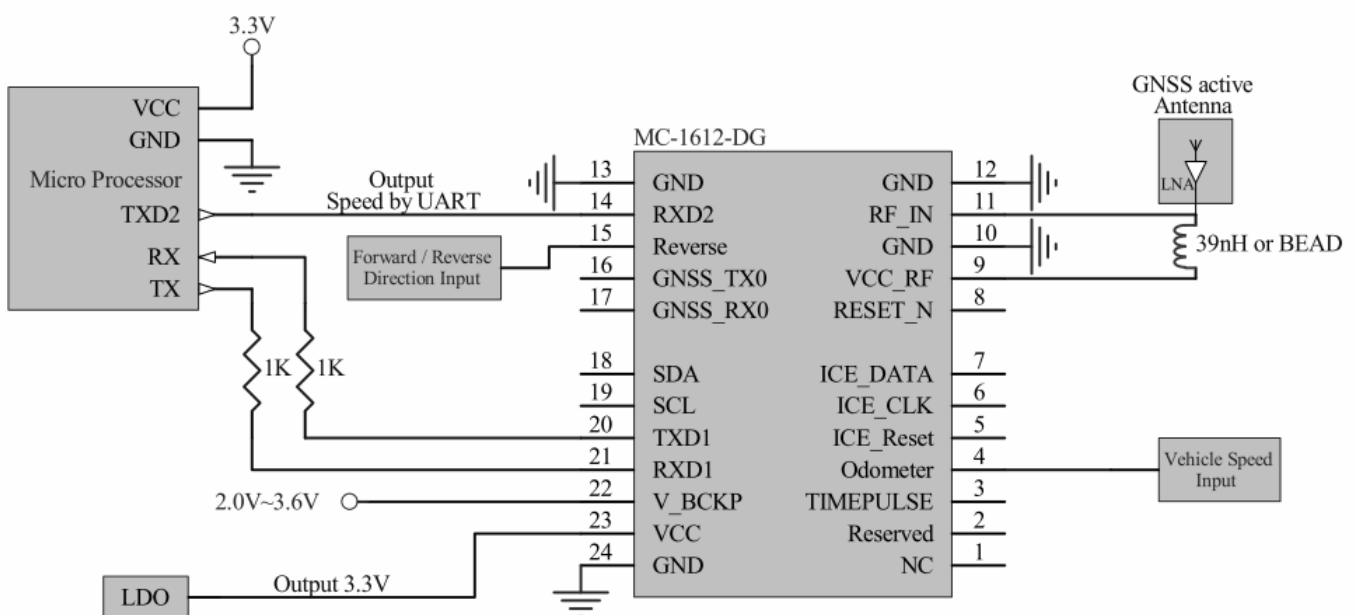

Fig 4-1 System block diagram.

5 Typical application circuit



## 6 GNSS receiver

### 6.1 GNSS receiver characteristics

Chip	GNSS chip	
Frequency	GPS, GALILEO, QZSS: L1 1575.42MHz, C/A code GLONASS: L1 1598.0625MHz ~ 1605.375MHz, C/A code	
Channels	Support 99 channels (33 Tracking, 99 Acquisition)	
Update rate	1Hz default, up to 10Hz (Option)	
MEMS Raw data update rate	100Hz	
Sensitivity	Tracking	up to -163dBm (with external LNA)
	Cold start	up to -148dBm (with external LNA)
Acquisition Time	Hot start (Open Sky)	<1 s (typical)
	Cold Start (Open Sky)	34s (typical)
Position Accuracy	Autonomous	2.5m (CEP)
	SBAS	2.5m (CEP, depends on accuracy of correction data)
	ADR Mode <sup>(2)</sup>	Avg 0.5 % <sup>(3)</sup>
	UDR Mode <sup>(2)</sup>	Avg 5.0 % <sup>(3)</sup>
Max. Altitude	< 18,000 m	
Max. Velocity	< 515 m/s	
Protocol Support	NMEA 0183 V4.10	115200 bps <sup>(4)</sup> , 8 data bits, no parity, 1 stop bits (default) 1Hz: GGA, GLL, GSA, GSV, RMC, VTG, GST, PLSVD, PINVMSLOPE and PINVMATTIT

Note 1: MC-1612-DG module is default configured for concurrent GPS, GLONASS, QZSS and SBAS reception.

Please contact us for different default configuration, such as concurrent GPS, GLONASS, GALILEO, QZSS and SBAS

Note 2: Typical Error incurred without GNSS as a percentage of distance travelled.

Note 3: Distance travelled (without GNSS)

Note 4: Both baud rate and output message rate are configurable to be factory default.

### 6.2 MEMS Sensor

The MC-1612-DG receiver support Dead Reckoning (DR) function, it composed by a 3-axis Gyroscope, 3-axis Accelerometer & pressure sensor (option). To provide optimal solution it needs to calibrate sensor parameters. The sensor parameters are initialized to default values allowing system to start up when no other better information is available, if system is started for the first time in an unknown vehicle gyroscope dedicated maneuvers are required and algorithms able to estimate these parameters.

### 6.3 Sensor data input

There are two methods to feed data to receiver as below descriptions.

- (1) Feed through vehicle Odometer (wheel-tick pulse) input.
- (2) Feed through the UART port; please refer to section 15.2 (UART input reference circuit) for more details.

## 7 Pin assignment and descriptions

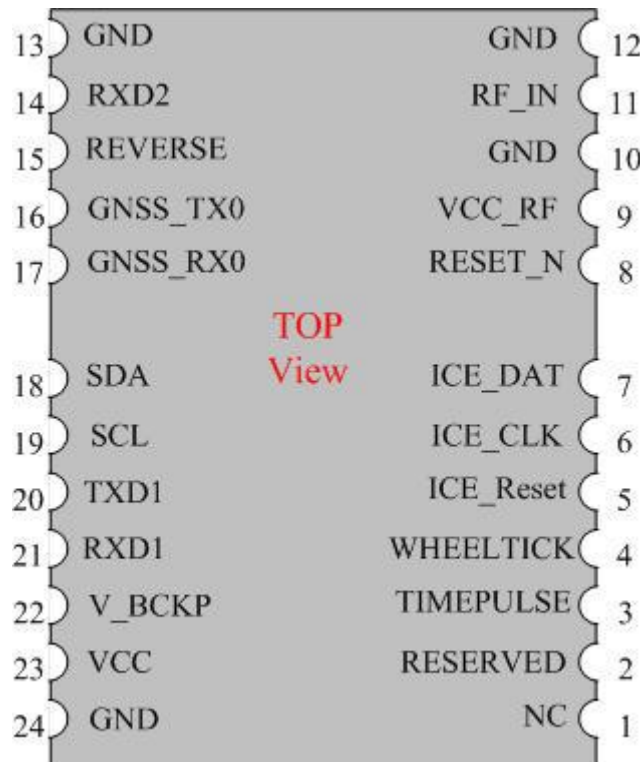

Table 7-1 Pin descriptions

Pin #	Name	Type	Description	Note
1	NC		Not connected	
2	RESERVED		Reserved, keep floating	
3	TIMEPULSE	O	Time pulse (1PPS, default 100 ms pulse/sec when 3D fix is available)	
4	WHEELTICK	I	Odometer wheel-tick input. If no use, please do not connection. <b>Attention: If the Odometer wheel-tick input is not used, the algorithm will automatically transfer to UDR mode.</b>	1
5	ICE_Reset		Micro processor program only	
6	ICE_CLK		Micro processor program only	
7	ICE_DAT		Micro processor program only	
8	RESET_N	I	RESET_N	
9	VCC_RF	O	Output voltage for active antenna	
10	GND	P	Ground	

11	RFIN	I	GNSS RF signal input	
12	GND	P	Ground	
13	GND	P	Ground	
14	RXD2	I	UART, asynchronous input <b>Attention: If the UART vehicle speed input is not used, the algorithm will automatically transfer to UDR mode.</b>	
15	Reverse	I	Direction of travel relative to vehicle frame	1
16	GNSS_TX0	O	UART TX0, for GNSS chip program only. If no use, please do not connection.	2
17	GNSS_RX0	I	UART RX0, for GNSS chip program only. If no use, please do not connection.	2
18	SDA		I2C,Sensor data output	
19	SCL		I2C,Sensor data output	
20	TXD1	O	UART, asynchronous output (Default NMEA)	
21	RXD1	I	UART, asynchronous input (Default NMEA)	
22	V_BCKP	P	Backup battery supply voltage	3
23	VCC	P	DC supply voltage	
24	GND	P	Ground	

Note 1: Pin4 and Pin15 needs external level shift circuits to meet DC electrical characteristics.

Note 2: If needs program GNSS chip, please pull low pin5 when VCC plug-in.

Note 3: The module doesn't have hot start when this pin and VCC pin are not applied.

## 8 DC & Temperature characteristics

### 8.1 Absolute maximum ratings

Parameter	Symbol	Ratings	Units
Input Voltage	VCC	3.6	V
Input Backup Battery Voltage	V_BCKP	3.6	V
Operating Temperature Range	Topr	-40 ~ 85	°C
Storage Temperature Range	Tstg	-40 ~ 85	°C

### 8.2 DC Electrical characteristics

Parameter	Symbol	Conditions	Min.	Typ.	Max.	Units
Input Voltage	VCC		3.0	3.3	3.6	V
Input Backup Battery Voltage	V_BCKP		2.0		3.6	V
VCC_RF Output Voltage	VCC_RF			VCC		V
Supply Current	I <sub>ss</sub>	VCC = 3.3V, w/o active antenna, Peak Acquisition Tracking			284	mA
				83		mA
				85 <sup>(1)</sup>		mA
Backup Battery Current	I <sub>bat</sub>	VCC = 0V		30		uA
VCC_RF Output Current	I <sub>out</sub>	VIN = 3.3V			25	mA
High Level Input Voltage	V <sub>IH</sub>		2.0		3.6	V
Low Level Input Voltage	V <sub>IL</sub>		-0.3		0.8	V
High Level Output Voltage	V <sub>OH</sub>		2.6			V
Low Level Output Voltage	V <sub>OL</sub>				0.4	V

Note1: Measured when position fix (1Hz) is available and input voltage is 3.3V with UART interface.

### 8.3 Temperature characteristics

Parameter	Symbol	Min.	Typ.	Max.	Units
Operating Temperature	Topr	-40	-	85	°C
Storage Temperature	Tstg	-40	25	85	°C

## 9 Installation and calibration

The module must be rigidly fixed on the vehicle before power-on. No requirement for installation orientation. Do not move the module after power-on. The module is only suitable for vehicle navigation with acceleration less than 2g.

In order to get the better fused navigation, the initialization and calibration steps are suggested in the following.

1. Power on the module and wait GNSS position fix in the open sky environment.
2. Stay still for about 180 second or more.
3. Drive in the straight road at the speed above 30km/h for more than 5 minutes in the open sky environment.
4. Accelerate and decelerate linearly more than 5 times in the open sky environment.
5. Complete 2 or more 90-degree turns in the open sky environment.
6. The system ready flag in the message "\$PINVMINR" shows if the fused PVT is ready.

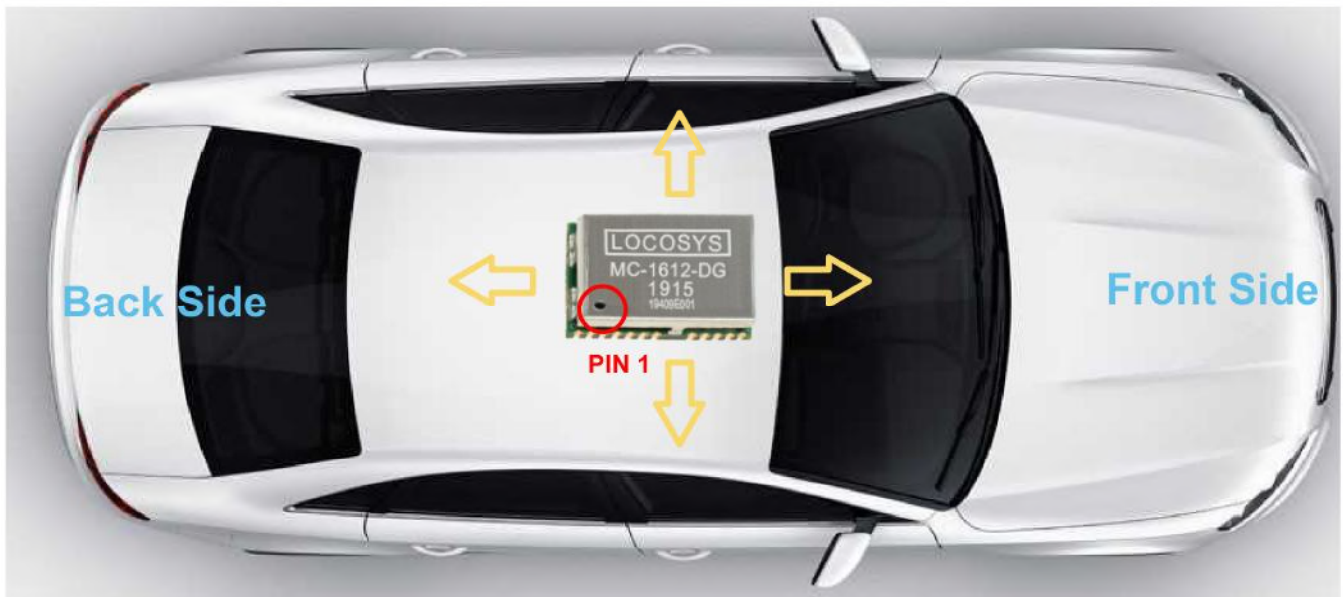



10 Outline dimensions

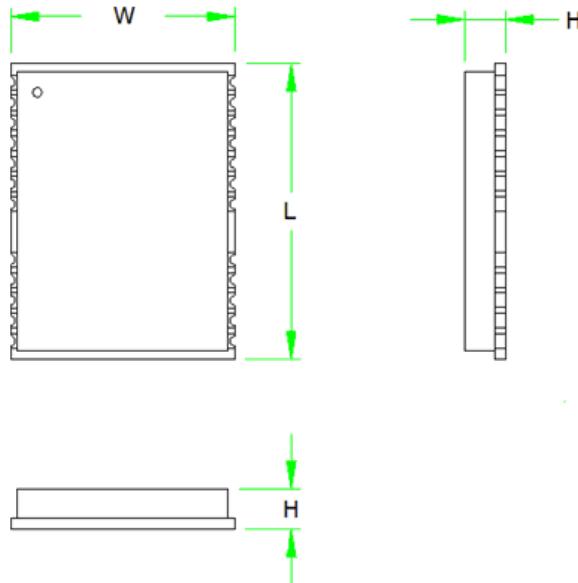

Symbol	Min. (mm)	Typ. (mm)	Max. (mm)
W	12.1	12.2	12.3
L	15.7	16.0	16.4
H	2.2	2.4	2.6

10.1 Recommended land pattern dimensions

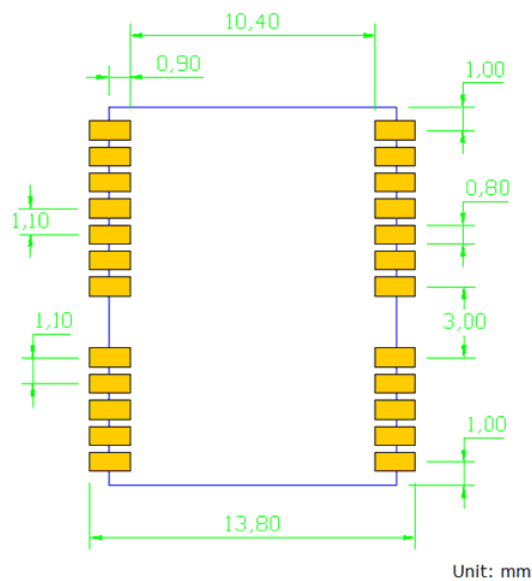

Note: The recommended land pattern dimensions are shown for reference only, as actual pad layouts may vary depending on application.

## 11 Software interface

### 11.1 NMEA output message

Table 11.1-1 NMEA output message

NMEA record	Description
GGA	Global positioning system fixed data
GLL	Geographic position - latitude/longitude
GSA	GNSS DOP and active satellites
GSV	GNSS satellites in view
RMC	Recommended minimum specific GNSS data
VTG	Course over ground and ground speed
PLSVD	3D velocity & deviation information
GST	Estimated Position Error

- **GGA--- Global Positioning System Fixed Data**

Table 11.1-2 contains the values for the following example:

\$GNGGA,084624.00,2504.78431,N,12141.77429,E,2,20,0.59,29.7,M,15.5,M,,0000\*7C

Table 11.1- 2 GGA Data Format

Name	Example	Units	Description
Message ID	\$GNGGA		GGA protocol header GN for GPS+GLONASS+(GALILEO) ; GP for GPS only
UTC Time	084624.00		hhmmss.ss
Latitude	2504.78431		ddmm.mmmmm
N/S indicator	N		N=north or S=south
Longitude	12141.77429		dddmm.mmmmm
E/W Indicator	E		E=east or W=west
Position Fix Indicator	2		See Table 11.1-3
Satellites Used	20		Range 0 to 33
HDOP	0.59		Horizontal Dilution of Precision
MSL Altitude	29.7	meters	
Units	M	meters	
Geoid Separation	15.5	meters	
Units	M	meters	
DGPS Age			Not supported
DGPS Reference	0000		
Checksum	*7C		

<CR> <LF>			End of message termination
-----------	--	--	----------------------------

Table 11.1-3 Position Fix Indicators

Value	Description
0	Fix not available or invalid
1	GNSS fix valid
2	Differential GNSS fix valid
3-5	Not supported
6	Estimated (Dead Reckoning) Mode

Note: It can bet DGPS (RTCM) or SBAS

### ● GLL--- Geographic Position – Latitude/Longitude

Table 11.1-4 contains the values for the following example:

\$GNGLL,2504.78431,N,12141.77429,E,084624.00,A,D\*7C

Table 11.1-4 GLL Data Format

Name	Example	Units	Description
Message ID	\$GNGLL		GLL protocol header GN for GPS+GLONASS+(GALILEO) ; GP for GPS only
Latitude	2504.78431		ddmm.mmmmm
N/S indicator	N		N=north or S=south
Longitude	12141.77429		dddmm.mmmmm
E/W indicator	E		E=east or W=west
UTC Time	084624.00		hhmmss.ss
Status	A		A=data valid or V=data not valid
Mode	D		A=autonomous, D=DGPS, E=DR, N=Data not valid, R=Coarse Position, S=Simulator
Checksum	*7C		
<CR> <LF>			End of message termination

### ● GSA---GNSS DOP and Active Satellites

Table 11.1-5 contains the values for the following example:

\$GNGSA,A,3,17,02,05,25,19,06,09,13,30,,1.02,0.72,0.72,1\*02

\$GNGSA,A,3,86,65,72,87,,,,,1.02,0.72,0.72,2\*06

\$GNGSA,A,3,09,05,,,,,1.02,0.72,0.72,3\*0C

Table 11.1-5 GSA Data Format

Name	Example	Units	Description
Message ID	\$GNGSA		GSA protocol header GN for GPS+GLONASS+(GALILEO) ; GP for GPS only

Mode 1	A		See Table 11.1-6
Mode 2	3		See Table 11.1-7
ID of satellite used	01		Sv on Channel 1
ID of satellite used	194		Sv on Channel 2
....			....
ID of satellite used			Sv on Channel 12
PDOP	0.92		Position Dilution of Precision
HDOP	0.59		Horizontal Dilution of Precision
VDOP	0.70		Vertical Dilution of Precision
GNSS System ID	1		1: GPS, 2: GLONASS, 3: GALILEO, 4: BEIDOU, 5-F: Reserved
Checksum	*01		
<CR> <LF>			End of message termination

Table 11.1-6 Mode 1

Value	Description
M	Manual- forced to operate in 2D or 3D mode
A	Automatic-allowed to automatically switch 2D/3D

Table 11.1-7 Mode 2

Value	Description
1	Fix not available
2	2D
3	3D

## ● GSV---GNSS Satellites in View

Table 11.1-8 contains the values for the following example:

```
$GPGSV,4,1,14,19,63,128,43,42,54,141,36,06,49,033,44,17,48,137,47,0*65
$GPGSV,4,2,14,05,42,252,45,02,41,325,43,09,35,063,38,12,27,284,39,0*66
$GPGSV,4,3,14,23,06,040,32,13,06,192,38,25,04,315,36,193,0*6A
$GPGSV,4,4,14,194,00,195,00,0*61
$GLGSV,2,1,06,68,71,209,40,82,55,059,42,67,49,028,40,81,22,113,35,1*74
$GLGSV,2,2,06,69,20,208,39,83,00,1*48
$GAGSV,1,1,04,26,00,36,08,00,43,07,00,43,03,00,35,0*7B
```

Table 11.1-8 GSV Data Format

Name	Example	Units	Description
Message ID	\$GPGSV		GSV protocol header, GP includes GPS, SBAS and QZSS Satellites in view; GL means GLONASS; GA means

			GALILEO
Total number of messages <sup>1</sup>	4		Range 1 to 4
Message number <sup>1</sup>	1		Range 1 to
Satellites in view	14		
Satellite ID	19		Channel 1 (Range 01 to 196) GPS Satellites ID : 01~32, SBAS Satellites ID : 33~64, & QZSS Satellites ID : 193~196
Elevation	63	degrees	Channel 1 (Range 00 to 90)
Azimuth	128	degrees	Channel 1 (Range 000 to 359)
SNR (C/No)	43	dB-Hz	Channel 1 (Range 00 to 99, null when not tracking)
....			....
Satellite ID	17		Channel 4 (Range 01 to 196)
Elevation	48	degrees	Channel 4 (Range 00 to 90)
Azimuth	137	degrees	Channel 4 (Range 000 to 359)
SNR (C/No)	47	dB-Hz	Channel 4 (Range 00 to 99, null when not tracking)
Signal ID	0		See Table 11.1-9
Checksum	*65		
<CR> <LF>			End of message termination

Note: Depending on the number of satellites tracked multiple messages of GSV data may be required.

Table 11.1-9 GNSS Identification:

System	System ID	Satellite ID	Signal ID	Signal Channel
GPS	1 (GP)	1 - 32 is reserved for GPS	0	All signals
		33 - 64 is reserved for SBAS	1	L1 C/A
GLONASS	2 (GL)	65 - 99 is reserved for GLONASS	0	All signals
			1	L1 C/A
GALILEO	3 (GA)	1 - 36 is reserved for GALILEO	0	All signals
			1	E5a

● **RMC---Recommended Minimum Specific GNSS Data**

Table 11.1-10 contains the values for the following example:

\$GNRMC,083353.00,A,2503.40802,N,12137.99014,E,0.014,58.94,130519,,,D,V\*32

Table 11.1-10 RMC Data Format

Name	Example	Units	Description
Message ID	\$GNRMC		RMC protocol header GN for GPS+GLONASS+(GALILEO) ; GP for GPS only
UTC Time	083353.00		hhmmss.ss

Status	A		A=data valid or V=data not valid
Latitude	2503.40802		ddmm.mmmmm
N/S Indicator	N		N=north or S=south
Longitude	12137.99014		dddmm.mmmmm
E/W Indicator	E		E=east or W=west
Speed over ground	0.014	knots	True
Course over ground	58.94	degrees	
Date	130519		ddmmyy
Magnetic variation		degrees	(Not shown)
Variation sense			E=east or W=west (Not shown)
Mode	A		A=autonomous, D=DGPS, E=DR, N=Data not valid, R=Coarse Position, S=Simulator
Navigational status	V		S=safe, C=caution, U=unsafe, V=Navigational status not valid
Checksum	*32		
<CR> <LF>			End of message termination

● **VTG---Course Over Ground and Ground Speed**

Table 11.1-11 contains the values for the following example:

\$GNVTG,58.94,T,,M,0.014,N,0.026,K,D\*17

Table 11.1-11 VTG Data Format

Name	Example	Units	Description
Message ID	\$GPVTG		VTG protocol header GN for GPS+GLONASS+(GALILEO) ; GP for GPS only
Course over ground	58.94	degrees	Measured heading
Reference	T		True
Course over ground		degrees	Measured heading (Not shown)
Reference	M		Magnetic (Not shown)
Speed over ground	0.014	knots	Measured speed
Units	N		Knots
Speed over ground	0.026	km/hr	Measured speed
Units	K		Kilometer per hour
Mode	D		A=autonomous, D=DGPS, E=DR, N=Data not valid, R=Coarse Position, S=Simulator
Checksum	*17		
<CR> <LF>			End of message termination

● **PLSVD---3D velocity & deviation information**

Table 11.1-12 contains the values for the following example:

\$PLSVD,-1,2,-1,17,17,14\*6A

Table 11.1-12 PLSVD Data Format

Name	Example	Units	Description
Message ID	\$PLSVD		PLSVD protocol header
True east velocity	-1	cm/s	-51500~51500
True north velocity	2	cm/s	-51500~51500
True down velocity	-1	cm/s	-10000~10000
Deviation of east velocity	17	cm/s	
Deviation of north velocity	17	cm/s	
Deviation of down velocity	14	cm/s	
Checksum	*6A		
<CR> <LF>			End of message termination

● **GST---Estimated Position Error**

Table 11.1-13 contains the values for the following example:

\$GNGST,083353.000,4.0,3.0,1.5,136.9,0.47,0.46,0.46\*4A

Table 11.1-13 GST Data Format

Name	Example	Units	Description
Message ID	\$GNGST		GST protocol header
UTC Time	083353.000		hhmmss.sss
RMS value of the standard deviation of the ranges	4.0		
Standard deviation of semi-major axis of error ellipse	3.0	meters	0~9999999.99
Standard deviation of semi-minor axis of error ellipse	1.5	meters	0~9999999.99
Orientation of semi-major axis of error ellipse	136.9	degree	
Standard deviation of Latitude error	0.47	meters	
Standard deviation of Longitude error	0.46	meters	
Standard deviation of altitude error	0.46	meters	
Checksum	*4A		

<CR> <LF>		End of message termination
-----------	--	----------------------------

## 11.2 Proprietary Dead Reckoning input/output messages

Table 11.2-1 The table below summarizes the set of proprietary command sets for the MC-1612-DG

NMEA record	Description
\$PINVMINR	Calibration status
\$PINVMVGS	Speed message info
\$PINVCRES	Clear the NVM data
\$PINVCSTR	Start session
\$PSTMDRSENMSG	Sensor data over UART
\$PINVMSLOPE	SLOPE information
\$PLSC, FORWARD	Reverse signal for High-Level or Low-Level to switch
\$PLSC, SPDSRC	Vehicle speed for ODO/UART to switch
\$PLSC, MEMS	MEMS RAW-DATA message enable/disable
\$PINVMATTIT	ATTIT information

- **\$PINVMINR --- Calibration status**

Table 11.2-2 contains the values for the following example:

\$PINVMINR,1\*04

Table 11.2-2 \$PINVMINR Data Format

Name	Example	Units	Description
Message ID	\$PINVMINR		\$PINVMINR protocol header
Status	1		0:not initialized 1:calibrating/initializing 2:calibration done
Checksum	*04		
<CR> <LF>			End of message termination

Note: When GNSS positioning is valid, the message appears at NMEA sentence.

- **\$PINVMVGS --- Speed Message info.**

Table 11.2-3 contains the values for the following example:

\$PINVMVGS,2392.893,12.30,F\*5C

Table 11.2-3 \$PINVMVGS Data Format

Name	Example	Units	Description
Message ID	\$PINVMVGS		\$PINVMVGS protocol header
Time stamp	2392.893		microseconds
Current speed	12.30	Km/h	Speed over ground in kilometers per hour



Direction	F		Direction of travel relative to vehicle frame (1) F = Forward (2) R = Reverse (3) U = Unknown
Checksum	*76		
<CR> <LF>			End of message termination

Note1: When vehicle speed is received, the message appears at NMEA sentence.

Note2: If the MC-1612-DG connect vehicle speed via odometer or UART, please check this info form NMEA sentence, if not success, the algorithm will auto transfer to UDR mode.

- **\$PINVCRES ---Clear the NVM data**

Table 11.2-4 contains the values for the following example:

\$PINVCRES,0\*1A

Table 11.2-4 \$PINVCRES Data Format

Name	Example	Units	Description
Message ID	\$PINVCRES		\$PINVCRES protocol header
Value	0		Clear the NVM data
Checksum	*1A		
<CR> <LF>			End of message termination

Note: The command need collocation start session command.

- **\$PINVCSTR --- Start session**

Table 11.2-5 contains the values for the following example:

\$PINVCSTR,14\*3E

Table 11.2-5 \$PINVCSTR Data Format

Name	Example	Units	Description
Message ID	\$PINVCSTR		\$PINVCSTR protocol header
Value	14		Start session
Checksum	*3E		
<CR> <LF>			End of message termination

Note 1: The command need collocation clear NVM data command.

Note 2: First time to use needs to do DR calibration, please follow below chart.

**A Command example for DR recalibration:**

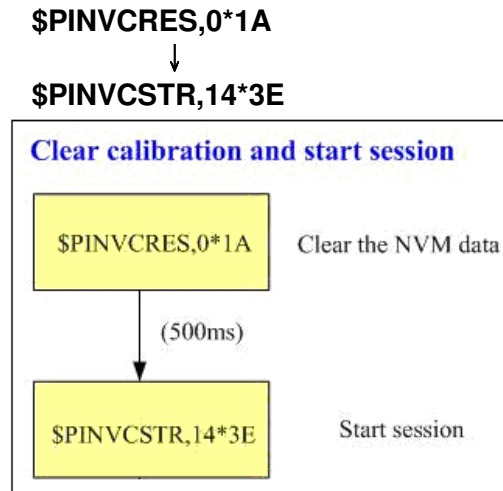

● **\$PSTMDRSENMSG --- Sensor data over UART**

Customer needs get vehicle speed from the micro processor and follow the table's data format to input MC-1612-DG module.

Table 11.2-6 contains the values for the following example:

\$PSTMDRSENMSG,14,0,31\*16

Table 11.2-6 \$ PSTMDRSENMSG Data Format

Name	Example	Units	Description
Message ID	\$PSTMDRSENMSG		\$PSTMDRSENMSG protocol header
MSG ID	14		Data type
MSG ID	0		Data type
Microprocessor output speed	31	Km/h	Speed over ground in kilometers per hour
Checksum	*16		
<CR> <LF>			End of message termination

Note: Default recommend input up to 5Hz to module pin14.

● **\$PINVMSLOPE --- SLOPE information**

Table 11.2-7 contains the values for the following example:

- a. Enable SLOPE (Default Enable)

\$PLSC,SLOPE,1\*78

\$PLSR,SLOPE,1,OK\*41

- b. Disable SLOPE

\$PLSC,SLOPE,0\*79

\$PLSR,SLOPE,0,OK\*40

\$PINVMSLOPE,-3.13,-0.05,0.93,54.42,2.60,1.86\*3B

\$PINVMSLOPE,2.07,0.38,10.66,55.95,2.20,1.49\*06

Table 11.2-7 \$PINVMSLOPE Data Format

Name	Example	Units	Description
Message ID	\$PINVMSLOPE		\$PINVMSLOPE protocol header
Slope	-3.13	degree	slope + : up ; - : down
Alt_Diff	-0.05	meters	altitude difference , + : up ; - : down
Move_Dist	0.93	meters	move distance
Slope_Accu	54.42	degree	slope accuracy
Alt_Diff_Accu	2.60	meters	altitude difference accuracy
Move_Dist_Accu	1.86	meters	move distance accuracy
Checksum	*3B		
<CR> <LF>			End of message termination

Note: Before testing can be done, make sure that the initialization and calibration have been completed.

- **\$PLSC,FORWARD<sup>(1)</sup> --- Reverse signal for High-Level or Low-Level to switch**

Table 11.2-8 contains the values for the following example:

- a. Reverse for High-Level  
 \$PLSC,FORWARD,0\*67  
 \$PLSR,FORWARD,0,OK\*5E
- b. Reverse for Low-Level  
 \$PLSC,FORWARD,1\*66  
 \$PLSR,FORWARD,1,OK\*5F
- c. Check status  
 \$PLSC,FORWARD,?\*68  
 \$PLSR,FORWARD,?,0\*65 : High-Level  
 \$PLSR,FORWARD,?,1\*64 : Low-Level

Table 11.2-8 \$PLSC,FORWARD Data Format

Name	Example	Units	Description
Message ID	\$PLSC,FORWARD		\$PLSC,FORWARD protocol header
MSG ID	0		High-Level=0 ; Low-Level=1
Checksum	*67		
<CR> <LF>			End of message termination

Note: The Forward /Reverse information only works with ODO-Type.

- **\$PLSC,SPDSRC --- Vehicle speed for ODO/UART to switch**

Table 11.2-9 contains the values for the following example:

- a. Vehicle speed to ODO-Type (Default ODO-Type)  
 \$PLSC,SPDSRC,ODO\*4D  
 \$PLSR,SPDSRC,ODO,OK\*74

- b. Vehicle speed to UART-Type(1) (Allow RXD1 and RXD2 use to vehicle speed input)  
 \$PLSC,SPDSRC,UART\*1B  
 \$PLSR,SPDSRC,UART,OK\*22

Table 11.2-9 \$PLSC,SPDSRC Data Format

Name	Example	Units	Description
Message ID	\$PLSC,SPDSRC		\$PLSC,SPDSRC protocol header
MSG ID	ODO		ODO-Type : ODO ; UART-Type : UART
Checksum	*4D		
<CR> <LF>			End of message termination

Note: Only be entered by one input source (RXD1 or RXD2) at the same time.

- **\$PLSC,MEMS --- MEMS RAW-DATA message enable/disable**

Table 11.2-10 contains the values for the following example:

- a. Enable MEMS RAW-DATA  
 \$PLSC,MEMS,1\*2B  
 \$PLSR,MEMS,1,OK\*12
- b. Disable MEMS RAW-DATA (Default Disable)  
 \$PLSC,MEMS,0\*2A  
 \$PLSR,MEMS,0,OK\*13

Table 11.2-10 \$PLSC,MEMS Data Format

Name	Example	Units	Description
Message ID	\$PLSC,MEMS		\$PLSC,MEMS protocol header
Enable/Disable	1		Enable : 1 ; Disable : 0
Checksum	*2B		
<CR> <LF>			End of message termination

※ MEMS RAW-DATA output message (Default 100Hz output)

Table 11.2-10-1 contains the values for the following example:

\$PINVMIMU,1114.106,-0.36990,1.51074,9.81383,0.67139,0.61035,-0.30518\*22

Table 11.2-10-1 \$PINVMIMU Data Format

Name	Example	Units	Description
Message ID	\$PINVMIMU		\$PINVMIMU protocol header
Time_Second	1114.106	sec	Time stamp
Accel_X	-0.36990	m/s <sup>2</sup>	Accel_X output data
Accel_Y	1.51074	m/s <sup>2</sup>	Accel_Y output data
Accel_Z	9.81383	m/s <sup>2</sup>	Accel_Z output data
Gyro_X	0.67139	degree /s	Gyro_X output data

Gyro_Y	0.61035	degree /s	Gyro_Y output data
Gyro_Z	-0.30518	degree /s	Gyro_Z output data
Checksum	*22		
<CR> <LF>			End of message termination

● **\$PINVMATTIT --- ATTIT information**

Table 11.2-11 contains the values for the following example:

- a. Enable ATTIT (Default Enable)  
 \$PLSC,ATTIT,1\*61  
 \$PLSR,ATTIT,1,OK\*58
- b. Disable ATTIT  
 \$PLSC,ATTIT,0\*60  
 \$PLSR,ATTIT,0,OK\*59

\$PINVMATTIT,-20.652,32.265,0.000\*3C

Table 11-2-11 \$PINVMATTIT Data Format

Name	Example	Units	Description
Message ID	\$PINVMATTIT		\$PINVMATTIT protocol header
Roll	-20.652	degree	Vehicle roll.
Pitch	32.265	degree	Vehicle pitch.
Heading(Yaw)	0.000	degree	Vehicle heading.
Checksum	*3C		
<CR> <LF>			End of message termination

Note: Before testing can be done, make sure that the initialization and calibration have been completed.

## 12 Recommended soldering reflow profile

The module belongs to RoHS device. The maximum of reflow temperature, real on top of PCB, is not over 240 Celsius.

### Lead-free Processes

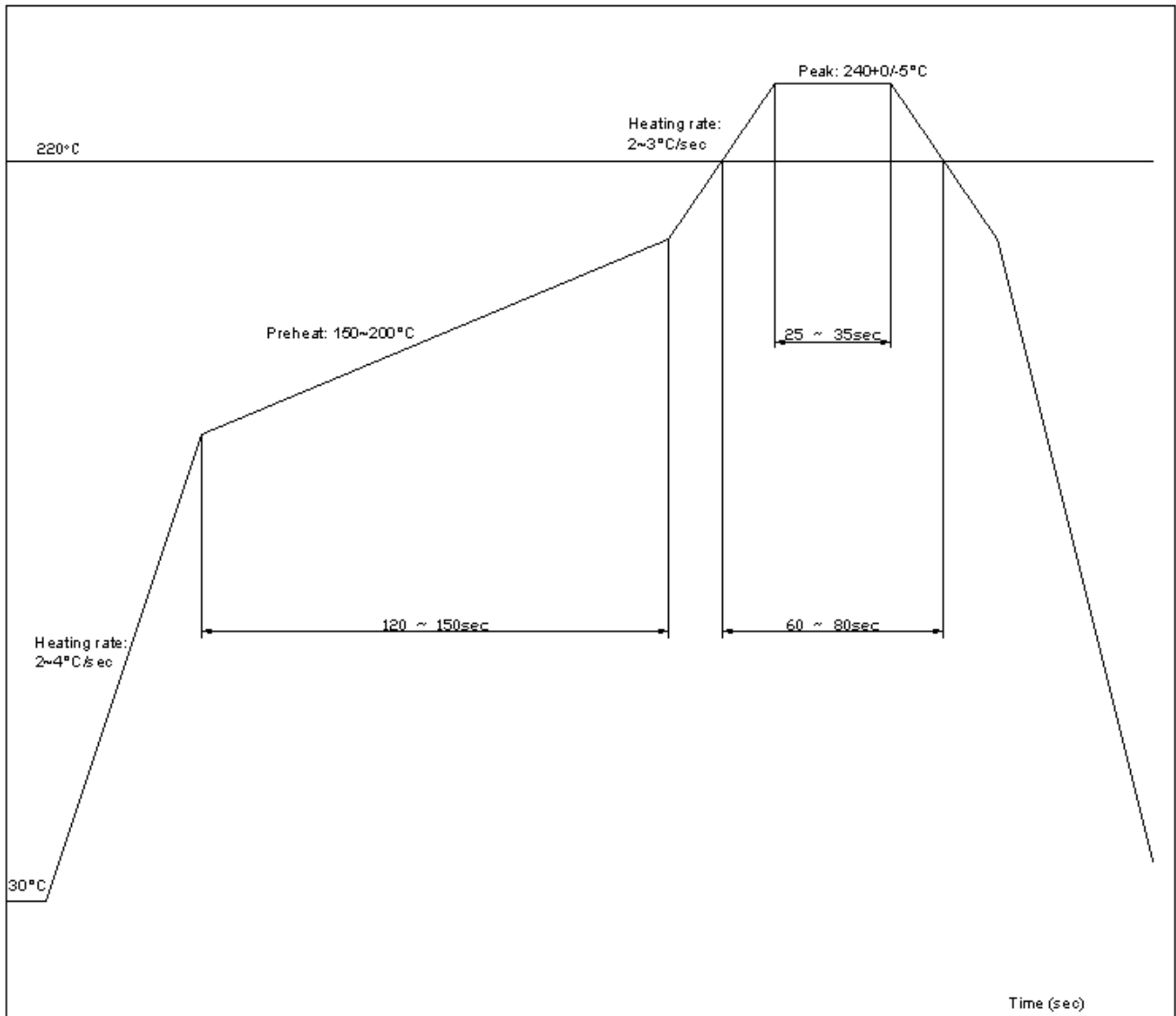

Lead-Free Solder Paste (Sn 96.5-Ag 3.0-Cu 0.5)

Cycle Interval: 300 sec

Note: The MC-1612-DG module should be soldered on the topside in the soldering process to prevent from falling down.

13 Reel packing information

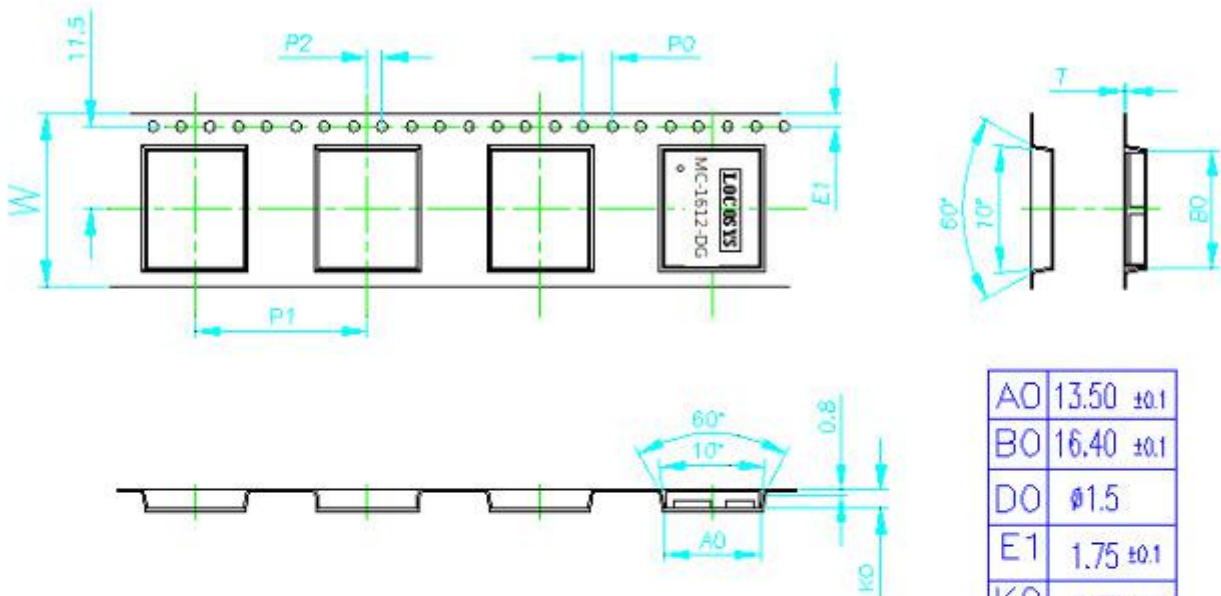

A0	13.50 ±0.1
B0	16.40 ±0.1
D0	∅1.5
E1	1.75 ±0.1
K0	2.70 ±0.1
P0	4.0 ±0.1
P1	24.00 ±0.1
P2	2.0 ±0.10
T	0.3 ±0.10
W	24.0 ±0.30

1. 10 sprocket hole pitch cumulative tolerance  $\pm 0.2$
2. Camber not to exceed 1mm in 100mm
3. A0 and B0 measured on a plane 0.3mm above the bottom of the pocket
4. K0 measured from a plane on the inside bottom of the pocket to the top surface of the carrier .
5. pocket position relative to sprocket hole measured as true position of pocket, not pocket hole.
6. Component load per 13" reel: 1000 pcs
7. Packing length per 22" reel: 75 M

## 14 Packing and Handling

GNSS modules, like any other SMD devices, are sensitive to moisture, electrostatic discharge, and temperature. By following the description sketched in the document for LOCOSYS GNSS module storage and handling, it is possible to reduce the chances of them being damaged during production.

### 14.1 Packing

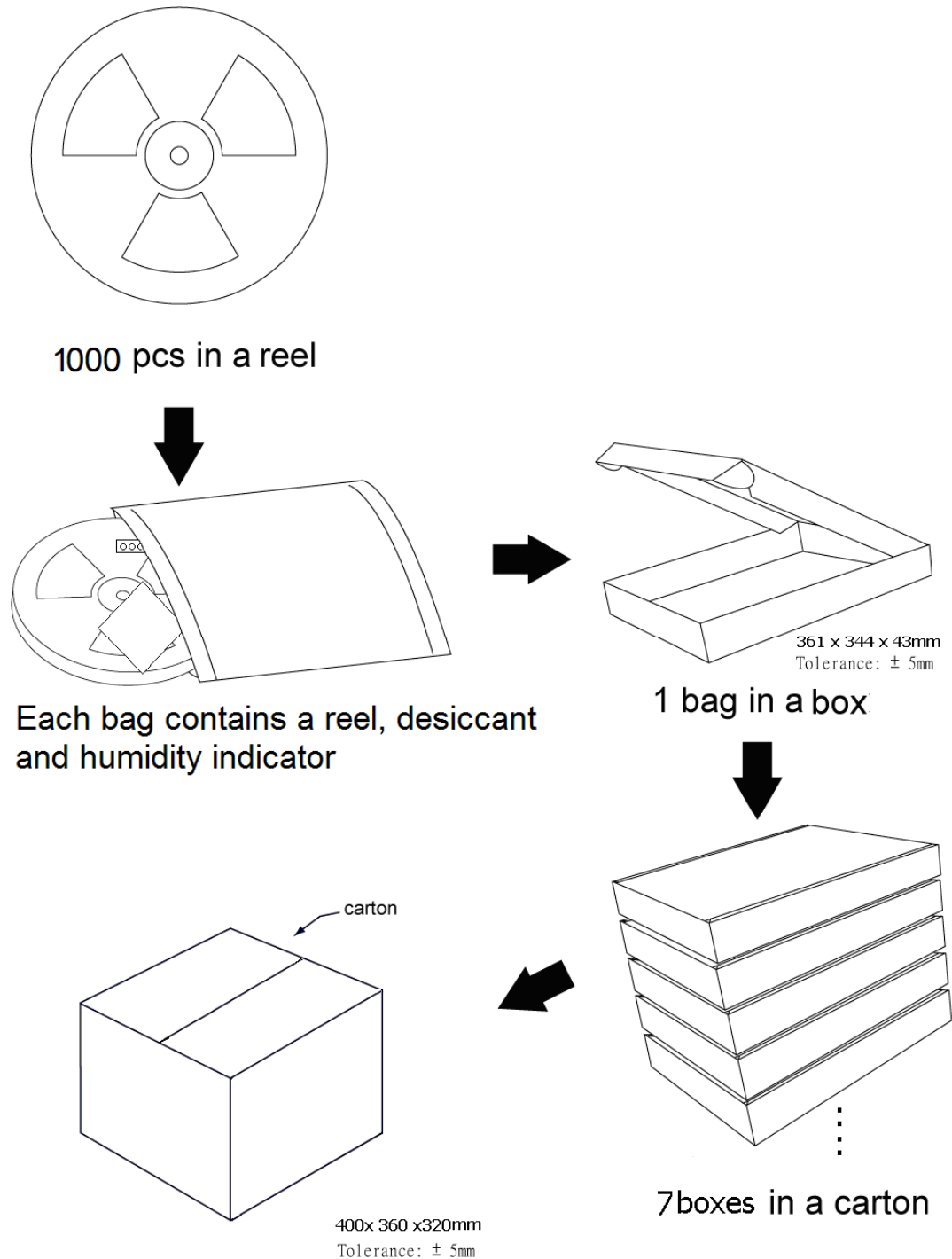



## 14.2 Moisture Sensitivity

The module belongs to moisture sensitive device (IPC/JEDEC J-STD-020C Level III). If it is not used by then, we strong recommended storing the GNSS modules in dry places such as dry cabinet. The approximate shelf life for LOCOSYS GNSS modules packages is 6 months from the bag seal date, when store in a non-condensing storage environment (<30°C/60% RH)

## 14.3 ESD Handling



**Please carefully follow the following precautions to prevent severe damage to GNSS modules.**

LOCOSYS GNSS modules are sensitive to electrostatic discharges, and thus are Electrostatic Sensitive Devices (ESD). Careful handling of the GNSS modules and in particular RFIN pin must follow the standard ESD safety protections:

- Unless there is a galvanic coupling between the local GND and the PCB GND, then the first point of contact when handling the PCB shall always be between the local GND and PCB GND.
- Before working with RFIN pin, please make sure the GND is connected.
- When working with RFIN pin, do not contact any charges capacitors or materials that can easily develop or store charges such as patch antenna, coax cable, soldering iron.
- When soldering RFIN pin, please make sure to use an ESD safe soldering iron (tip).

15 Reference Circuit

15.1 For Odometer (wheel-tick pulse) input reference

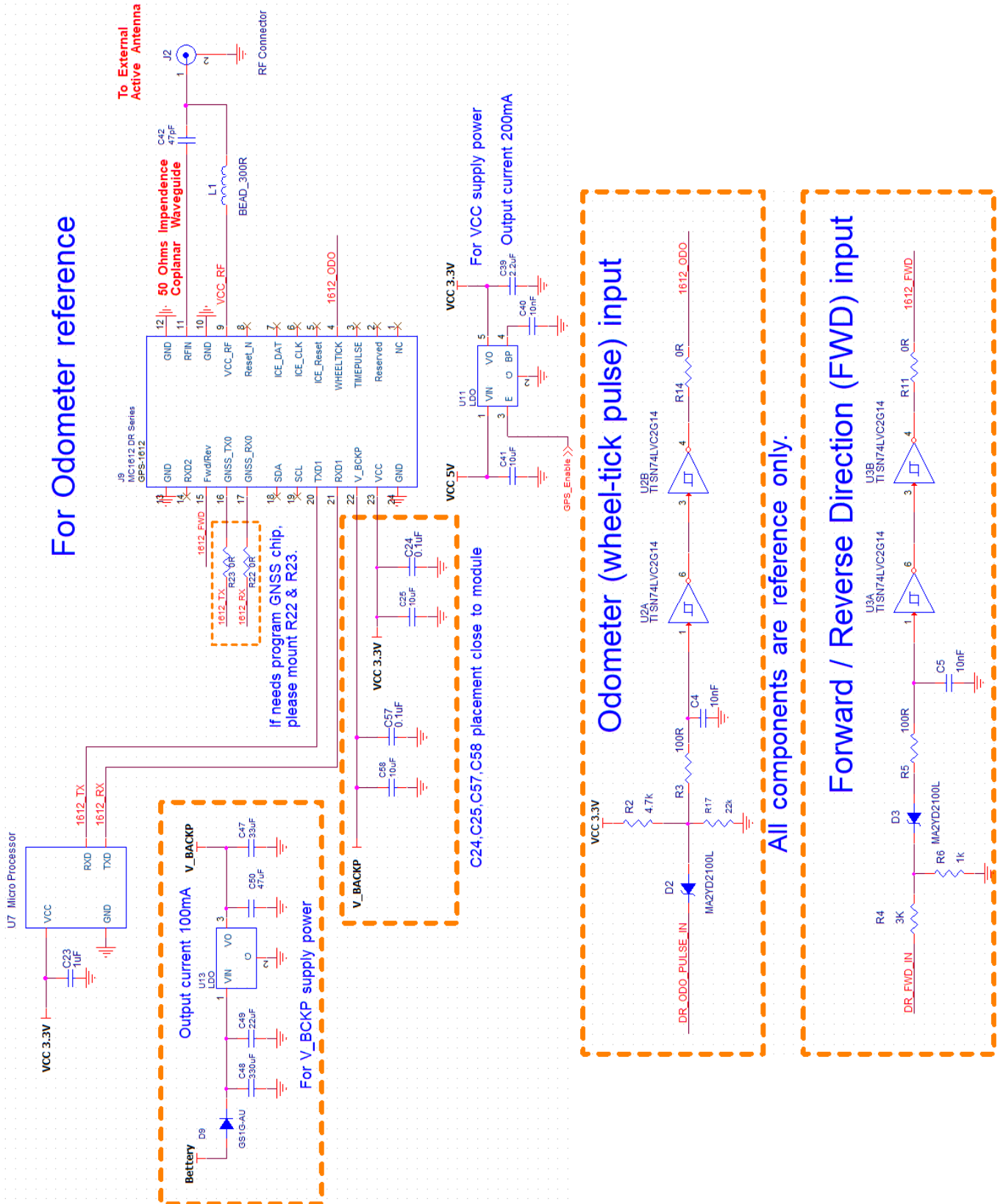

15.2 For UART input Reference

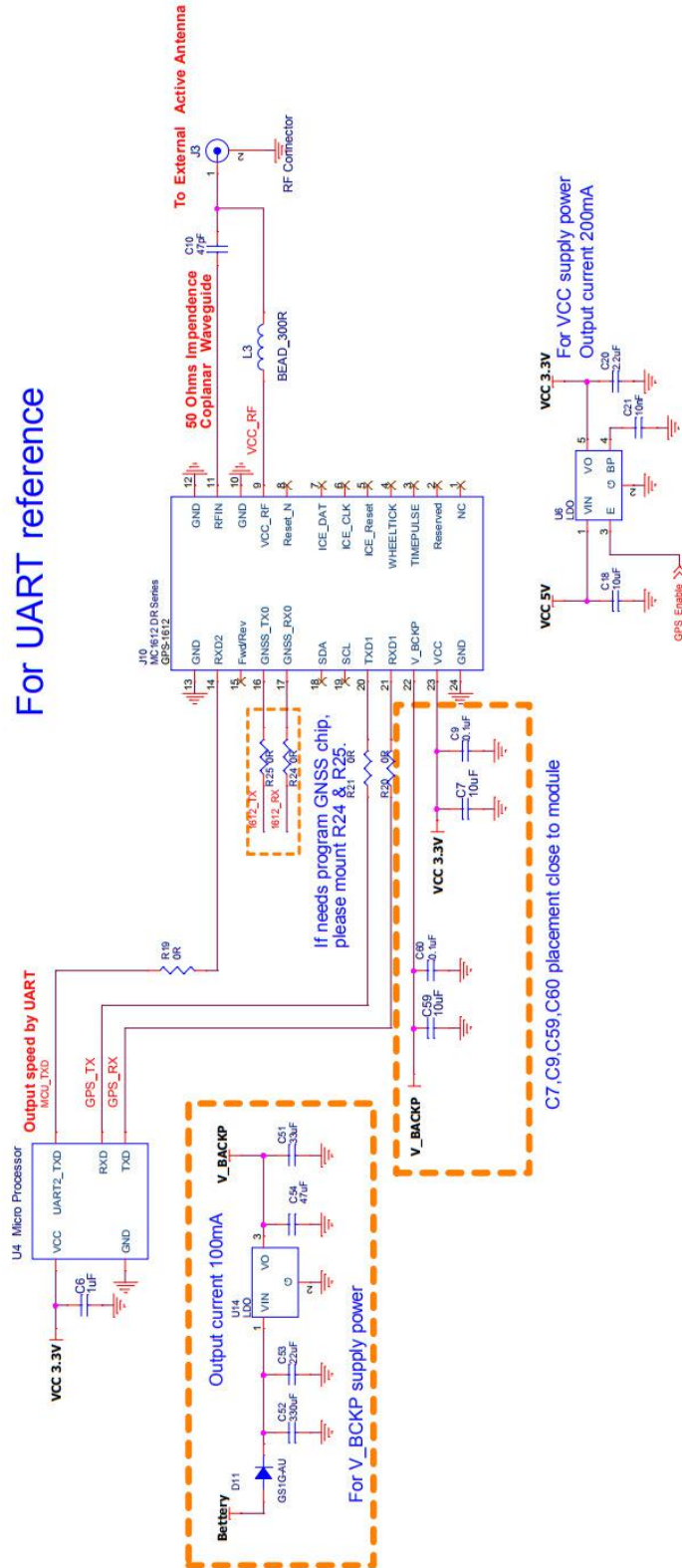

## Document change list

### Revision 0.1

- Draft release on May. 16, 2019

### Revision 0.2 (Aug.13.2019)

- Modify section 2 Features on page 2.
- Modify section 6.1 GNSS receiver characteristics on page 4.

### Revision 0.3 (Aug.21.2019)

- Modify section 5 Typical application circuit on page 3.
- Modify section 6.1 GNSS receiver characteristics on page 4.

### Revision 0.4 (Oct.23.2019)

- Modify section 6.3 Sensor data input on page 4.

### Revision 0.5 (Nov.05.2019)

- Modify section 9 Installation on page 8.
- Added section 11.2 the Proprietary Dead Reckoning input/output messages on page 21.

### Revision 0.6 (Apr.29.2020)

- Added “Note 1” in the section 6.1.

### Revision 0.7 (June.02.2020)

- Added “calibration step description” in the section 9.