

50Ω Wideband, 1.5 to 28 GHz

### The Big Deal

- Extremely Wideband, 1.5 to 28 GHz
- Very low insertion loss, 0.7 dB typ.
- Good return loss, 20 dB typ.
- Excellent Isolation, 47 dB typ.



CASE STYLE: JV2579

### Product Overview

Mini-Circuits' MBT-283+ is an ultra-wideband MMIC surface mount bias tee covering applications from 1.5 GHz to 28 GHz with low insertion loss, excellent return loss, and high DC-RF isolation over its entire frequency range. This model is capable of handling up to +30 dBm (1W) RF input power and DC input current up to 500mA. MBT-283+ is enclosed in a 3.5 x 2.5mm, 16-lead MCLP package for good thermal performance.

### Key Features

Feature	Advantages
Ultra-wideband, 1.5 to 28 GHz	Supports a wide range of applications with a single device, including biasing broadband amplifier, laser diodes, active antennas and more.
Low insertion loss, 0.7 dB	Preserves signal strength from input to output and minimizes overall system loss
Excellent return loss, 20 dB typ.	Provides excellent matching for 50 Ω systems with minimal signal reflection.
RF power handling up to 1W	This model supports applications with a variety of power requirements.
Excellent DC-RF isolation <ul style="list-style-type: none"> <li>• 59 dB, 1.5 to 10 GHz</li> <li>• 47 dB, 10 to 20 GHz</li> <li>• 48 dB, 20 to 28 GHz</li> </ul>	Minimizes RF leakage and interference with other elements in the system.

# MMIC Bias-Tee

## MBT-283+

50Ω Wideband, 1.5 to 28 GHz

### Product Features

- Extremely Wideband, 1.5 to 28 GHz
- Very low insertion loss, 0.7 dB typ.
- Good return loss, 20 dB typ.
- Excellent Isolation, 47 dB typ.
- Patent pending

### Typical Applications

- Biasing Amplifiers
- Biasing laser diodes
- Biasing of active antennas



Generic photo used for illustration purposes only

CASE STYLE: JV2579

#### +RoHS Compliant

The +Suffix identifies RoHS Compliance. See our web site for RoHS Compliance methodologies and qualifications

### General Description

Mini-Circuits' MBT-283+ is an ultra-wideband MMIC surface mount bias tee covering applications from 1.5 GHz to 28 GHz with low insertion loss, excellent return loss, and high DC-RF isolation over its entire frequency range. This model is capable of handling up to +30 dBm (1W) RF input power and DC input current up to 500mA. MBT-283+ is enclosed in a 3.5 x 2.5mm, 16-lead MCLP package for good thermal performance.

### simplified schematic & pad description

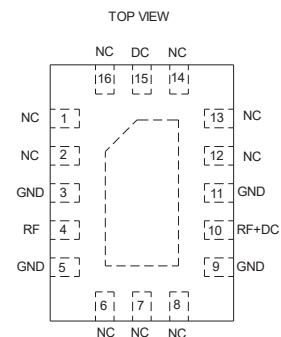
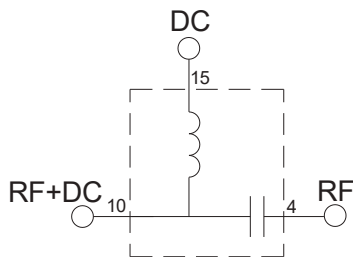

Function	Pad Number	Description
RF	4	RF Pad
RF + DC	10	RF + DC Pad
DC	15	DC Pad, Connects DC port via C1
N/C	1,2, 6-8, 12-14 & 16	No connection, grounded on Test Board.
GROUND	3,5,9,11 & Paddle	Ground

**Electrical Specifications<sup>1</sup> at 25°C, unless noted**

Parameter	Frequency (MHz)	Min.	Typ.	Max.	Units
Frequency Range		1500		28000	MHz
Insertion Loss	1500 - 10000		0.7	1.3	dB
	10000 - 20000		0.7	1.6	
	20000 - 25000		0.7	1.8	
	25000 - 28000		1.0	2.1	
Isolation (RF Port to DC Port)	1500 - 10000		57		dB
	10000 - 20000		47		
	20000 - 25000		48		
	25000 - 28000		47		
Return Loss	1500 - 10000		19		dB
	10000 - 20000		21		
	20000 - 25000		16		
	25000 - 28000		14		
DC resistance from DC to RF & DC port			2.7		Ohm

1. Measured on Mini-Circuits Characterization Test Board TB-MBT-283+. See Characterization Test Circuit (Fig. 1)

**Absolute Maximum Ratings<sup>2</sup>**

Parameter	Ratings
Operating Temperature	-40°C to 85°C
Storage Temperature	-65°C to 150°C
RF Power	30 dBm
Voltage at DC Port	35V
Current at DC Port	500mA

2. Permanent damage may occur if any of these limits are exceeded.

**Characterization Test & Application Circuit**

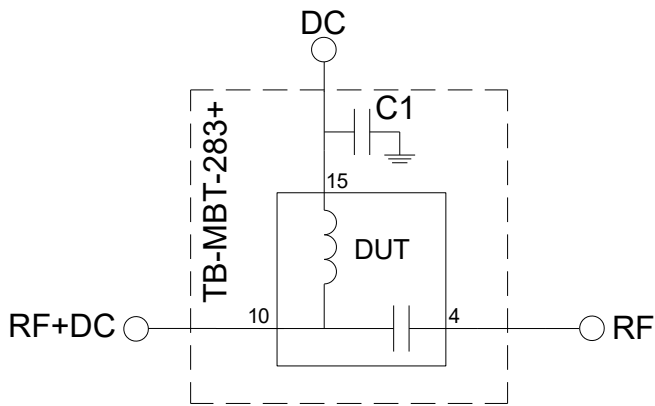

Component	Size	Value	Part Number	Manufacturer
C1	0402	0.1uF	GRM155R71H104KE14J	Murata

Fig 1. Block Diagram of Test Circuit used for characterization. Test Board TB-MBT-283+  
 Parameter to measure: Insertion Loss, Isolation, Return Loss  
 Condition: Pin = 0 dBm

**Product Marking**



Marking may contain other features or characters for internal lot control

<b>Additional Detailed Technical Information</b>	
<i>additional information is available on our dash board. To access this information <a href="#">click here</a></i>	
<b>Performance Data</b>	Data Table
	Swept Graphs
	S-Parameter (S3P Files) Data Set (.zip file)
<b>Case Style</b>	JV2579 Plastic package, exposed paddle, lead finish: Matte-Tin Plate
<b>Tape &amp; Reel</b> Standard quantities available on reel	F104 7" reels with 2K devices
<b>Suggested Layout for PCB Design</b>	PL-692
<b>Evaluation Board</b>	TB-MBT-283+ & TB-MBT-283C+
<b>Environmental Ratings</b>	ENV08T1

## ESD Rating

Human Body Model (HBM): Class 1B (500 V) in accordance with ANSI/ESD STM 5.1 - 2001

## MSL Test Flow Chart

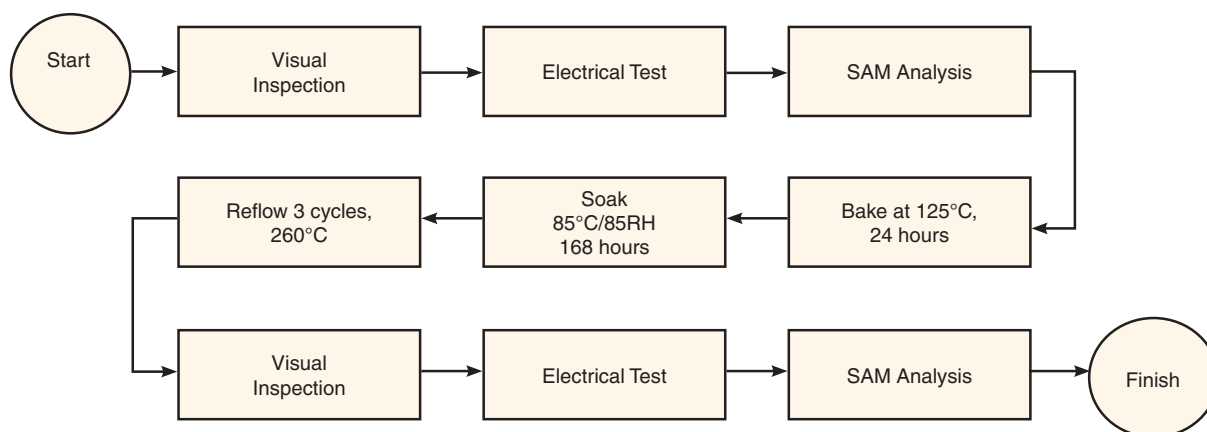

### Additional Notes

- Performance and quality attributes and conditions not expressly stated in this specification document are intended to be excluded and do not form a part of this specification document.
- Electrical specifications and performance data contained in this specification document are based on Mini-Circuit's applicable established test performance criteria and measurement instructions.
- The parts covered by this specification document are subject to Mini-Circuits standard limited warranty and terms and conditions (collectively, "Standard Terms"); Purchasers of this part are entitled to the rights and benefits contained therein. For a full statement of the Standard Terms and the exclusive rights and remedies thereunder, please visit Mini-Circuits' website at [www.minicircuits.com/MCLStore/terms.jsp](http://www.minicircuits.com/MCLStore/terms.jsp)